

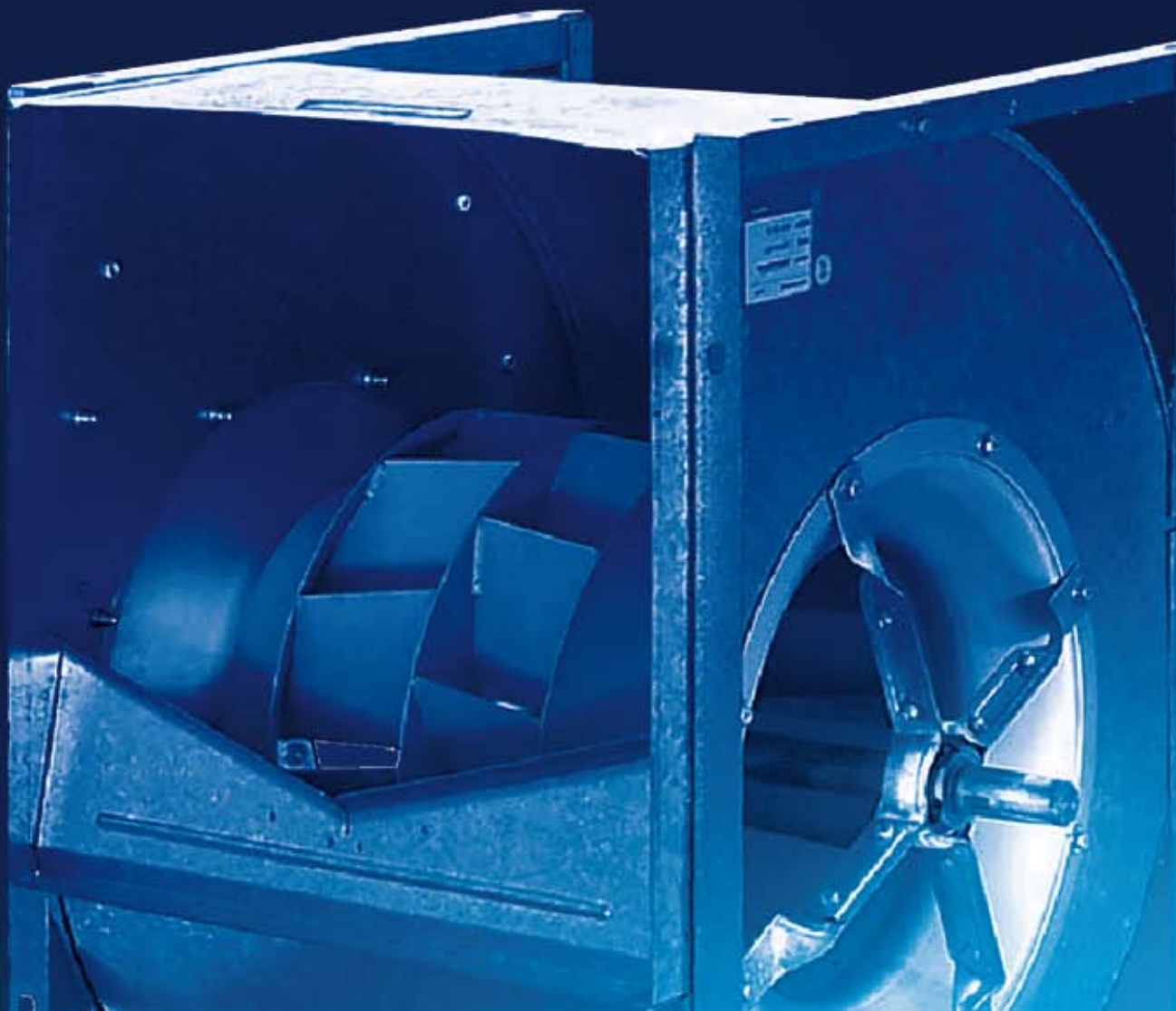

BDB

Double Inlet
Centrifugal Fan

with Backward Wheels size 200-280



S&P - LA EMPRESA

Desde su fundación en el año 1951, en la localidad de Ripoll (España), Soler & Palau, S.A. se ha convertido, desde hace ya bastantes años, en uno de los líderes mundiales en la fabricación y venta de todo tipo de equipos de ventilación y de extracción de aire.

Ocho plantas productivas y once empresas filiales propias de comercialización, ubicadas en diversos países y continentes constituyen el actual Grupo S&P que, con un cualificado equipo de más de 1300 personas, ejerce su actividad en todos los países del mundo.

S&P - THE COMPANY

Soler & Palau was founded in 1951 in Ripoll (Spain) and since this date has become one of the world's leading companies engaged in the manufacture, sales and distribution of all types of ventilating and air moving products. Today Soler & Palau has eight production plants and eleven wholly owned commercial subsidiary companies located across the globe. Supporting the design, development production and commercial facilities are a professional team of more than 1300 employees who ensure that Soler & Palau continue to have an active presence in all global market sectors.

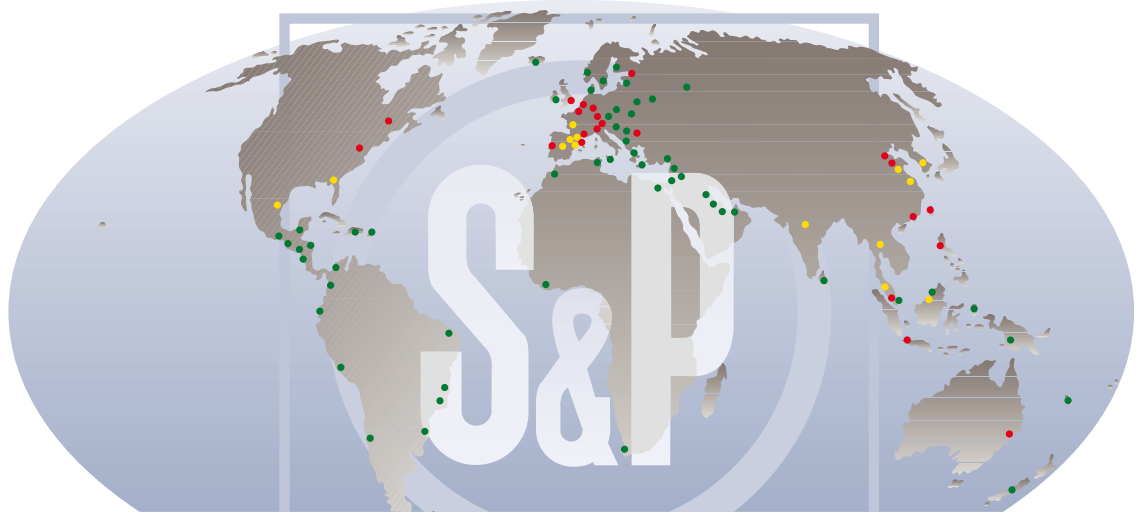

S&P - LA ESTRATEGIA

Investigación y Desarrollo de productos y tecnología propios; Calidad de producción por encima de la media de su campo de actividad y Vocación de Expansión sostenible son, y han sido entre otros, tres de los pilares fundamentales sobre los que descansa la trayectoria de Soler & Palau, S.A. Contar hoy con más de 60 Ingenieros titulados en las áreas de Investigación, Desarrollo, Innovación y Producción; Certificaciones ISO 9001:2000 y 14001:1996 acreditadas por AENOR (Soler & Palau fue la primera empresa registrada en España). Laboratorios propios de ensayo con certificación oficial EN-45001-89 y crecimientos anuales, sostenidos en las últimas décadas, muy superiores a los de su mercado son algunos de los logros de la correcta aplicación de la mencionada estrategia de empresa.

Nuevos y apasionantes proyectos que verán la luz muy en breve, están hoy en marcha en el Grupo S&P.

S&P - THE STRATEGY

At the heart of Soler & Palau's company strategy is the continued substantial investment in product and manufacturing research, development and quality control. Since 1951 the sustained investment in these critical areas has enabled Soler & Palau to offer to its customers products with unparalleled quality and reliability. These critical elements of success today form the fundamental cornerstones of the company's strategy for growth within increasingly competitive global markets.

Today Soler & Palau has more than 60 highly qualified engineers working in areas such as product and manufacturing technology research, development, innovation and production. The engineers work closely with international safety standards agencies to ensure that all of Soler & Palau's products are manufactured and supplied in accordance with only the very latest mechanical and electrical safety standards. All products are extensively tested with the company's comprehensive in-house airflow, acoustic and environmental test laboratories which have been officially certified by AENOR to EN-45001- 89 standards. Currently Soler & Palau hold both ISO 9001:2000 and ISO 14001:1996 certifications and were also the first company in Spain to be registered to the original ISO 9000 standards.

Through operating a continual rigorous program of new and existing product development and improvement means that Soler & Palau's customers are assured that they will continue to receive products of only the very highest quality and reliability both now and in the future.





BDB Series

DOUBLE INLET CENTRIFUGAL FAN
with Backward Wheels size 200-280

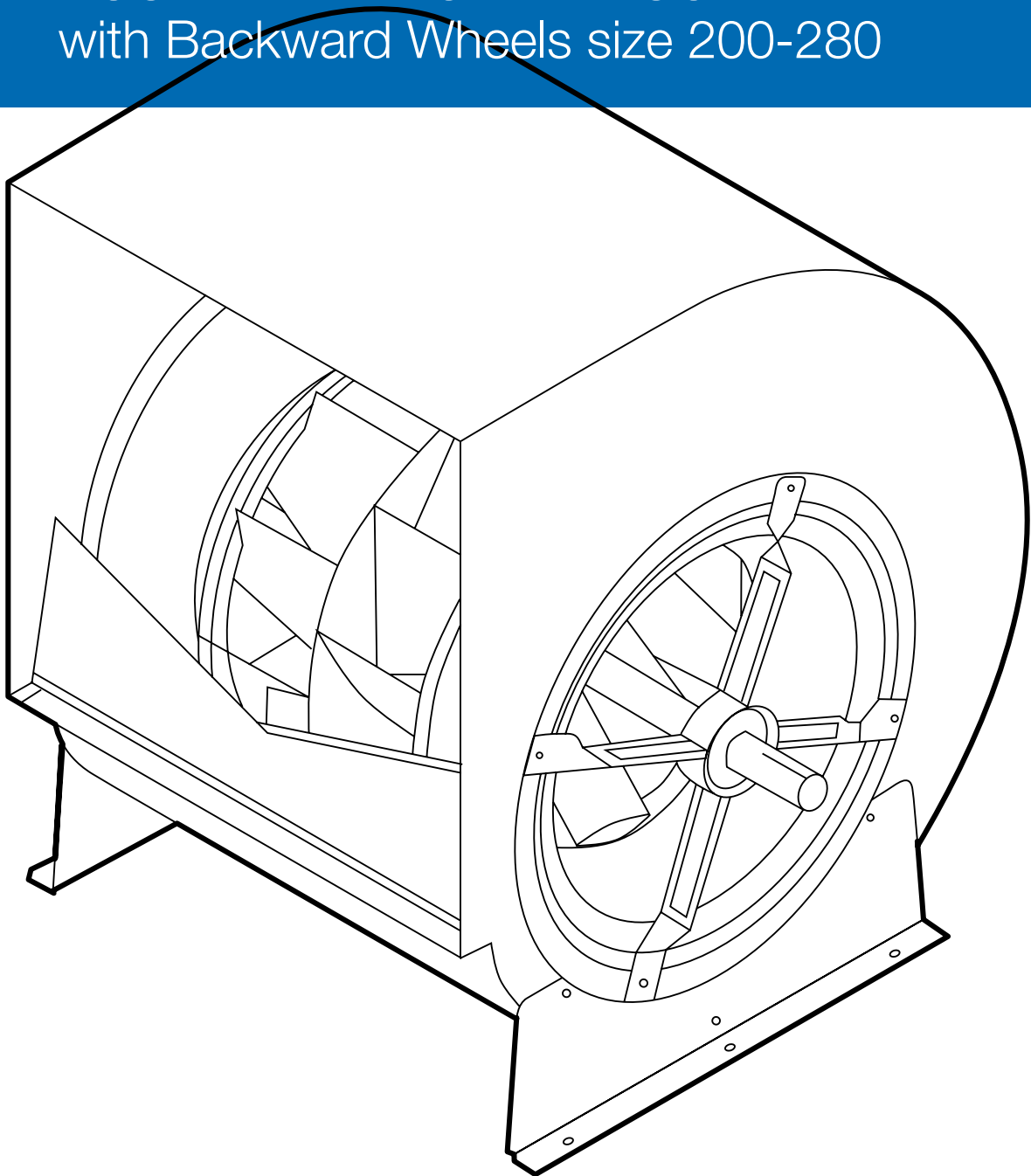

BDB Series

Double Inlet Centrifugal Fans – Backward wheels

The BDB series is DIDW centrifugal fans with high efficiency non-overloading backward curved impellers.

The fans are suitable for supply or extract applications in commercial, process and industrial HVAC systems.

Sizes of this series are in accordance with AMCA standard 99-0098-76 and DIN 323 R20.

Model 200 to 280

Type S-C	I
Type T	II

Type / Operating Limit

Each fan type has its maximum operating speed and power due to its mechanical design.

The operating limit of BDB series - fan type is design to meet the requirement of class I, II limit according AMCA STD 99-2408-69.

The BDB series is available in types S, C or T.

Type S

This type is designed to work with mounting feet and can be mounted in three different orientations.

The construction is mainly for OEM application which only subject to testing and approval.

Type C

This type has a frame fitted on both sides of the fan which gives better strength and rigidity.

It allows mounting in four different orientations.

Type T

This type has a welded frame giving increased stiffness and rigidity required for higher operating performance.

BDB Twin Fan

BDB Series are also available in twin fan version, with two double inlet fans mounted on the same shaft. To select for twin fans, use the curves of single fan with the following factors:

- Volume x 2
- Absorbed Power x 2.15
- Speed x 1.05
- Noise + 3 dB

This series is available in Type S2, C2 or T2 on request.

Technical Specification

Wheel

The wheel of BDB series is made of cold rolled sheet steel backward curved blades with polyester powder coating finish.

Housing

For all sizes, the housing is manufactured in galvanized sheet steel with the housing fixed to the side plates in "pittsburg lock" form system.

Frame

The frame is manufactured with galvanized angular bars for type "C". For type "T" is manufactured with sections of steel and finished with polyester powder coating.

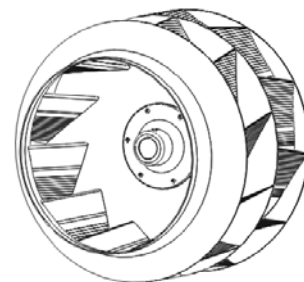

Shaft

Shafts are manufactured from C45 carbon steel using an automatic process for positioning and cutting of the keyways. All dimensional tolerances of the shaft are fully checked to ensure a precision fit and then coated with an anticorrosion varnish after assembly.

Bearings

Bearings used are either deep groove ball bearing type with an adaptor sleeve or spherical roller bearings type sealed at both sides for different duty application classified as below:

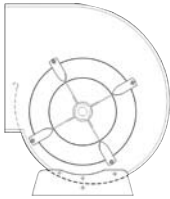
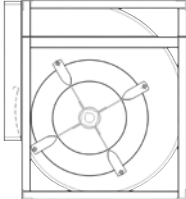
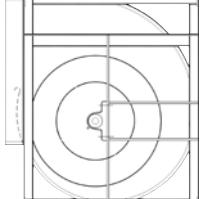
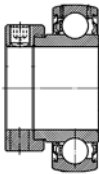
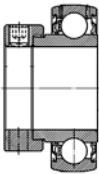
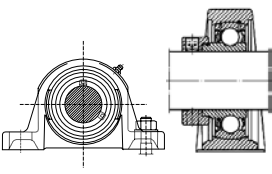
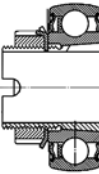
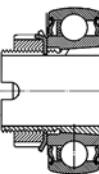
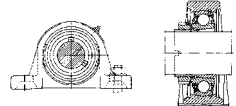
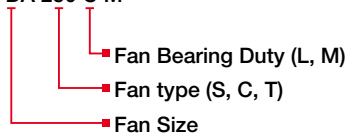
	Mounted in a rubber housing		Mounted on cast iron supports with grease point
	S	C	T
Fan Type			
Bearing Duty	SL Light Duty 	CL Light Duty 	TL Light Duty 
	SM Medium Duty 	CM Medium Duty 	TM Medium Duty 
	eg. Model FDA 450 C M		
	Model FDA 250 C M  <ul style="list-style-type: none"> ▪ Fan Bearing Duty (L, M) ▪ Fan type (S, C, T) ▪ Fan Size 		

The bearings are lubricated for life and maintenance-free. If relubrication is necessary, it is recommended to use a lithium base grease suitable for all temperatures within the operational limits.

Balancing Quality

All wheels are statically and dynamically balanced to ISO1940 - G 2,5 GRADE.

Accessories

Casing Drain

This option is available when using fans exposed to the atmosphere or operating in high humidity conditions.

Outlet Flanges

Outlet flanges are available upon request.

Inspection Doors

The inspection door can be supplied upon request. It can be supplied in one of the three positions (P3, P4 & P5).

Guards

Inlet guards, discharge guards and non-drive end shaft guards are available on request.

Paintings

Special powder-paint coatings of various thicknesses can be supplied on request.

Air flow measurement

Fans can be equipped with an airflow measurement system.

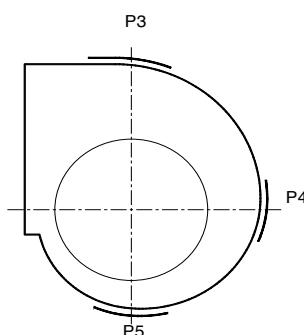

Fan Rotation and Discharge

The rotation and discharge of the fan is in accordance with AMCA standard 99-2406-83.

The direction of rotation is determined from the drive side of the fan:

CW - clockwise rotation

CCW - counter-clockwise rotation

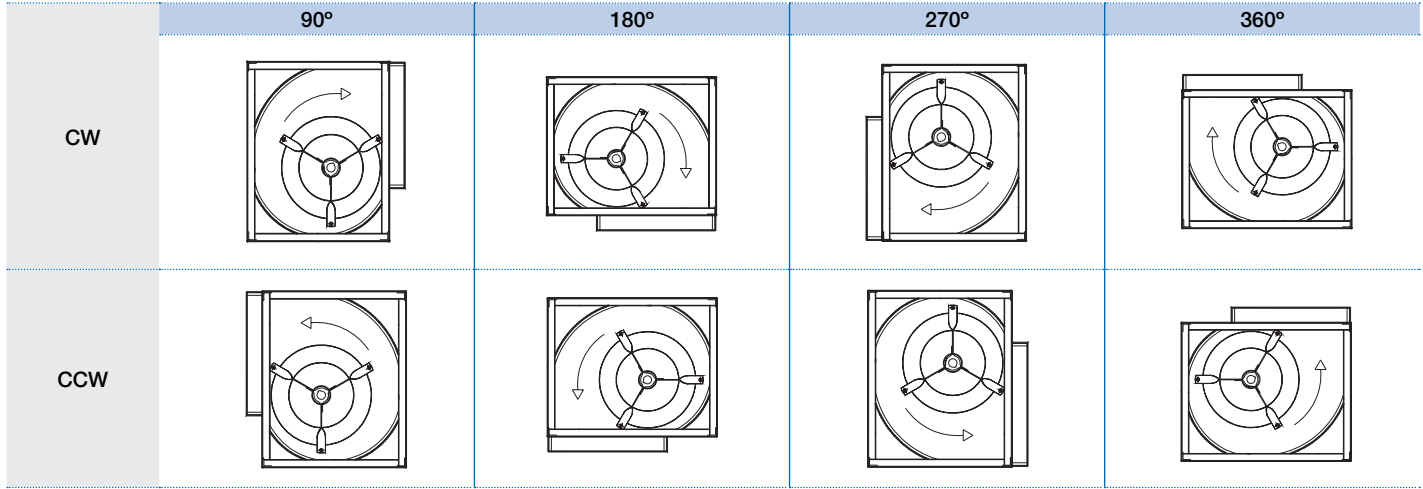

Motor Position

Location of motor is determined by facing the drive side of fan and designating the positions by letters W, X, Y, or Z

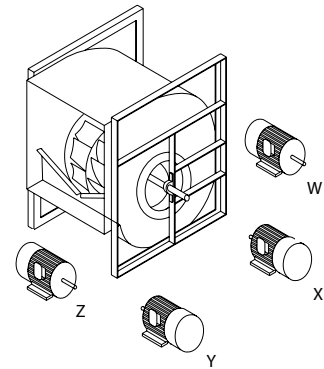

Motor Selection

The power curve shown on each performance curve represents the absorbed power at the shaft of the fan measured in kW.

To determine the power of the motor to be installed, a correction factors should be applied to compensate for transmission losses.

For conversion to horsepower (HP), use multiplying factor 1.34.

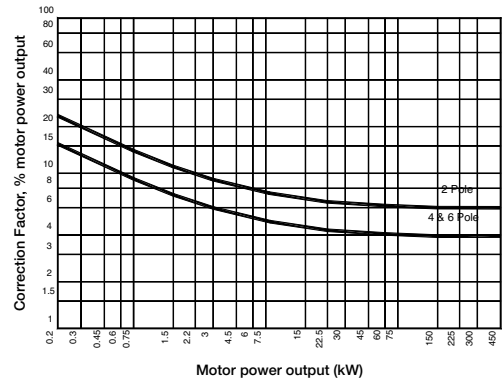

Example of Selection

BDB 225

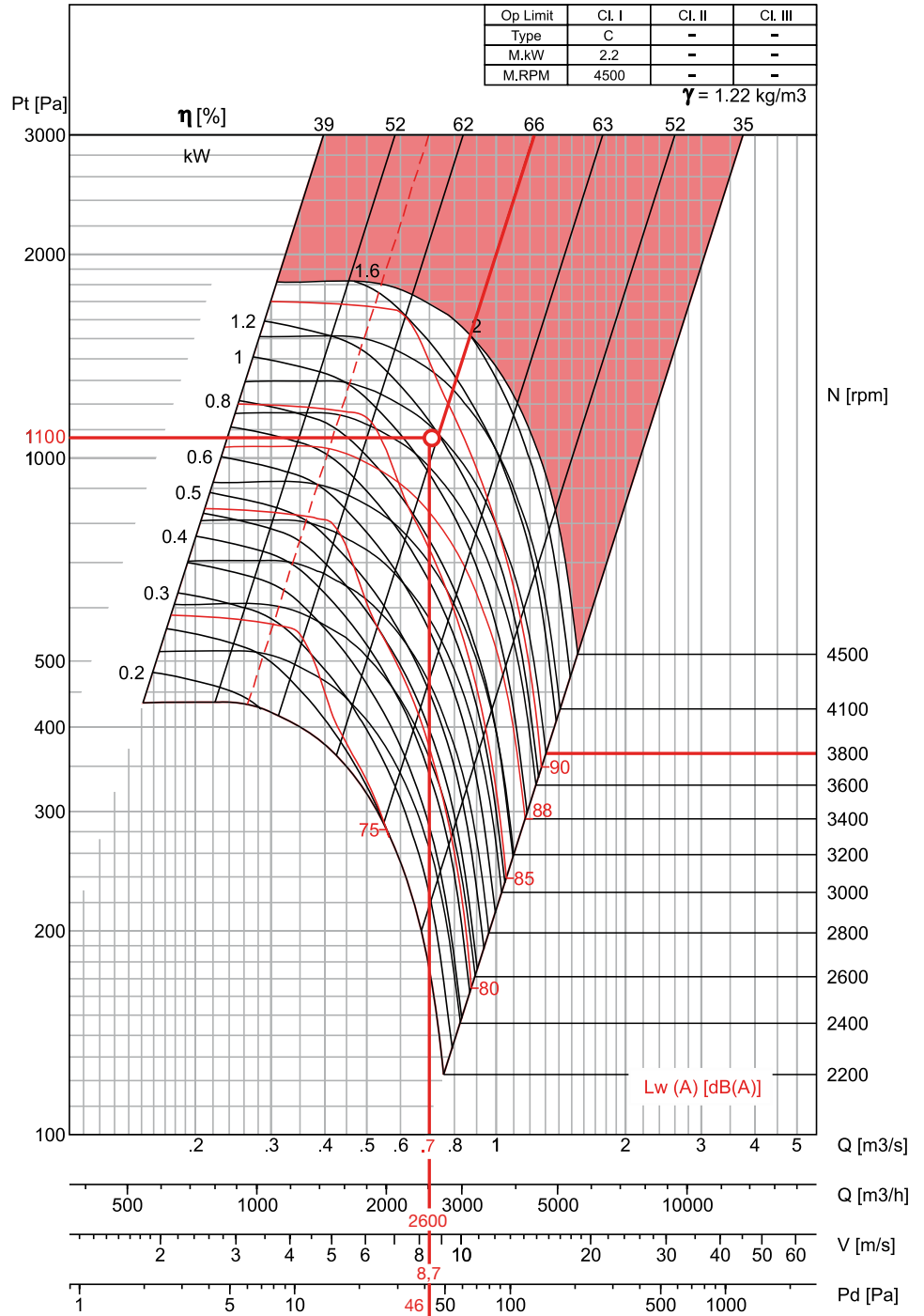

Air Volume $Q = 2600 \text{ m}^3/\text{h}$
 Outlet Velocity $V = 8.7 \text{ m/s}$
 Dynamic Pressure $Pd = 46 \text{ Pa}$
 Total Pressure $Pt = 1100 \text{ Pa}$
 Fan Speed $N = 3800 \text{ rpm}$
 Absorbed Power $W = 1.2 \text{ kW}$
 Total Efficiency $\eta = 66 \%$
 Sound Power Level $Lw(A) = 88 \text{ dB(A)}$

- Performance shown is for Installation type B - free inlet, ducted outlet. Performance ratings do not include the effects of appurtenances in the airstream. Power rating kW does not include drive losses.
 - The A-weighted sound ratings shown have been calculated per AMCA standard 301. Values shown are for inlet Lwi(A) sound power levels for installation type B - free inlet, ducted outlet. Ratings do not include the effect of duct end corrections.



BDB 200

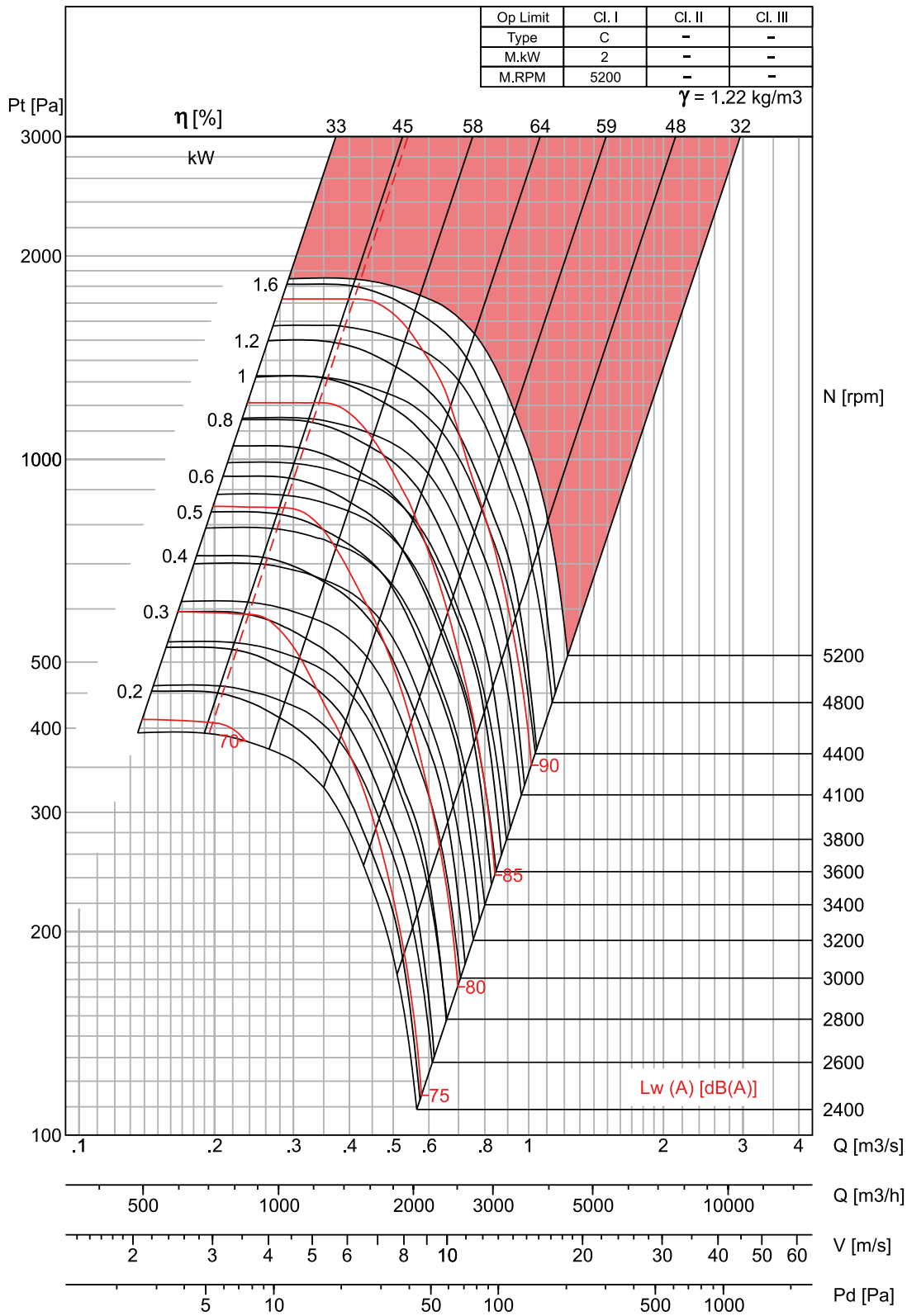

- Performance shown is for Installation type B - free inlet, ducted outlet. Performance ratings do not include the effects of appurtenances in the airstream. Power rating kW does not include drive losses.
 - The A-weighted sound ratings shown have been calculated per AMCA standard 301. Values shown are for inlet $L_{wi}(A)$ sound power levels for installation type B - free inlet, ducted outlet. Ratings do not include the effect of duct end corrections.

BDB 225

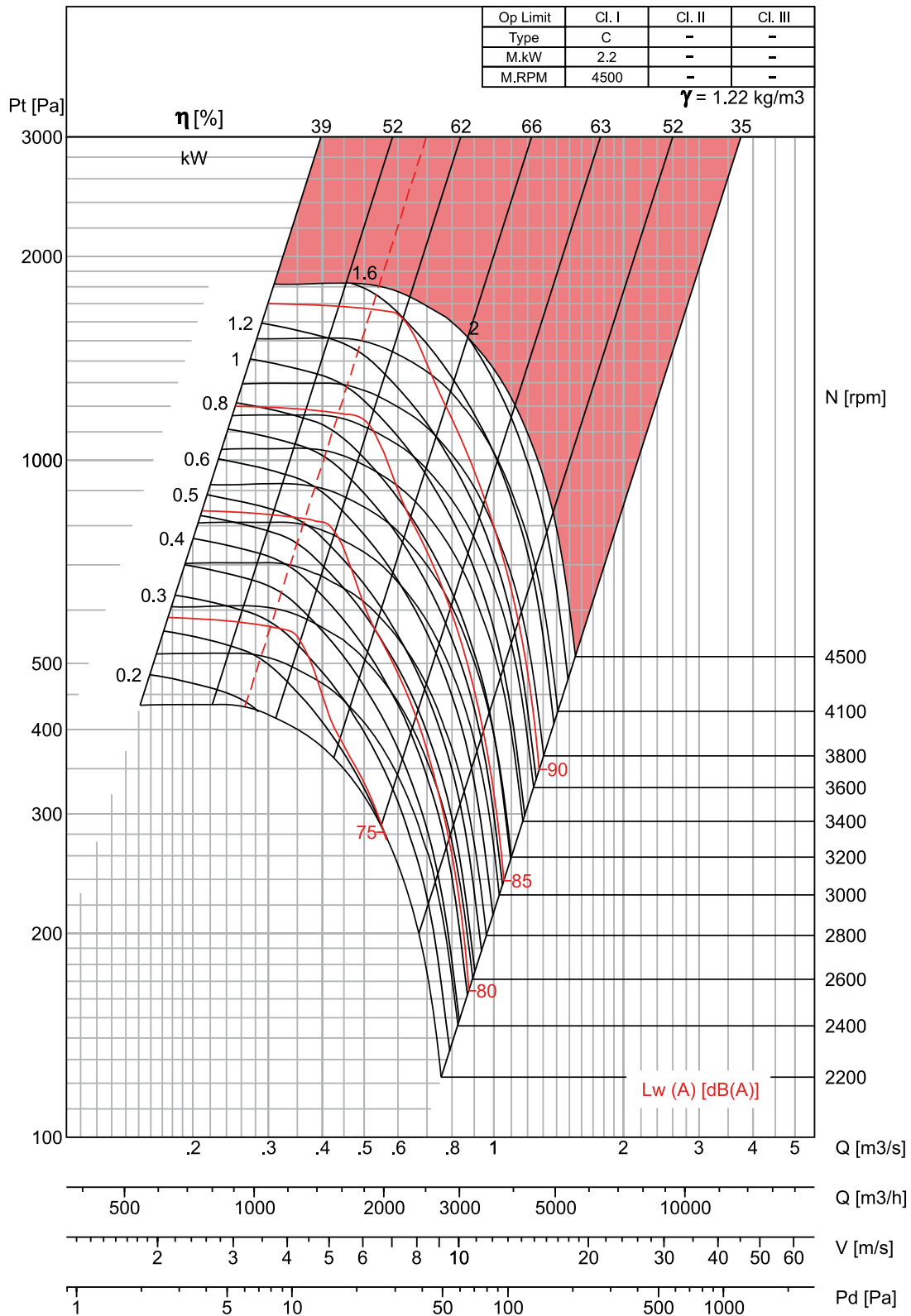

- Performance shown is for Installation type B - free inlet, ducted outlet. Performance ratings do not include the effects of appurtenances in the airstream. Power rating kW does not include drive losses.
 - The A-weighted sound ratings shown have been calculated per AMCA standard 301. Values shown are for inlet Lwi(A) sound power levels for installation type B - free inlet, ducted outlet. Ratings do not include the effect of duct end corrections.



BDB 250

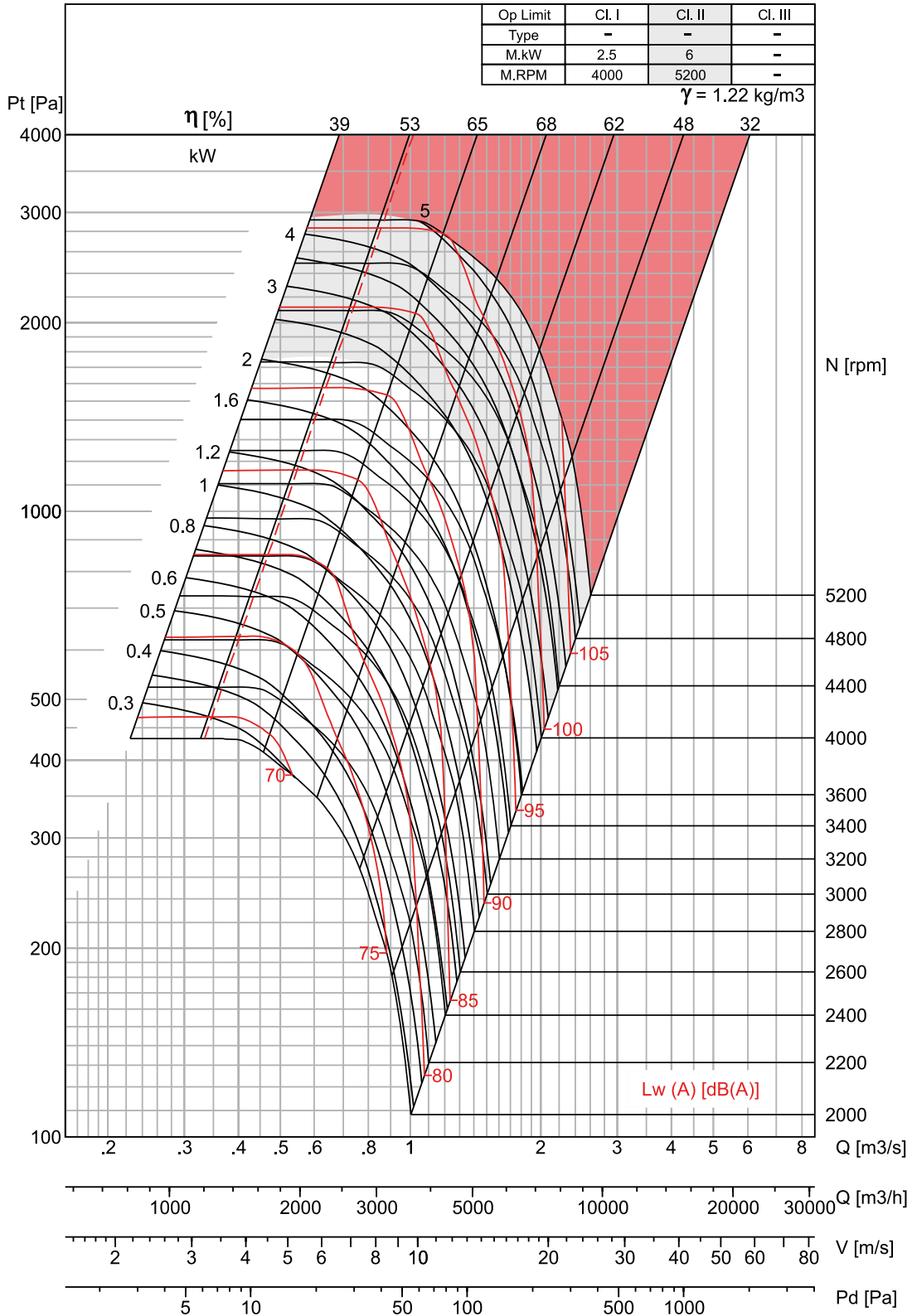

- Performance shown is for Installation type B - free inlet, ducted outlet. Performance ratings do not include the effects of appurtenances in the airstream. Power rating kW does not include drive losses.
 - The A-weighted sound ratings shown have been calculated per AMCA standard 301. Values shown are for inlet Lwi(A) sound power levels for installation type B - free inlet, ducted outlet. Ratings do not include the effect of duct end corrections.

BDB 280

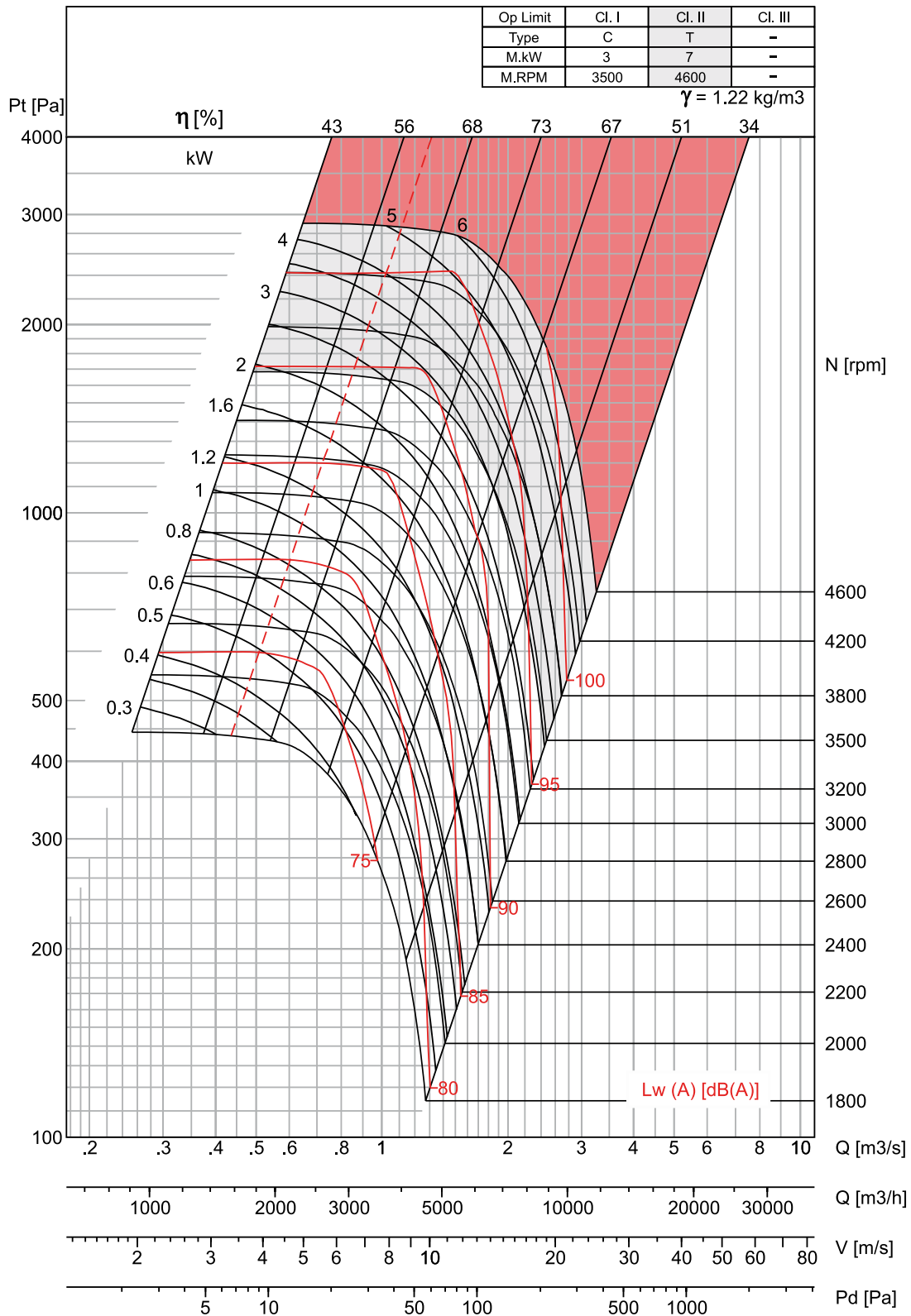

- Performance shown is for Installation type B - free inlet, ducted outlet. Performance ratings do not include the effects of appurtenances in the airstream. Power rating kW does not include drive losses.
 - The A-weighted sound ratings shown have been calculated per AMCA standard 301. Values shown are for inlet Lwi(A) sound power levels for installation type B - free inlet, ducted outlet. Ratings do not include the effect of duct end corrections.



BDB

BDB 200-280 'S'

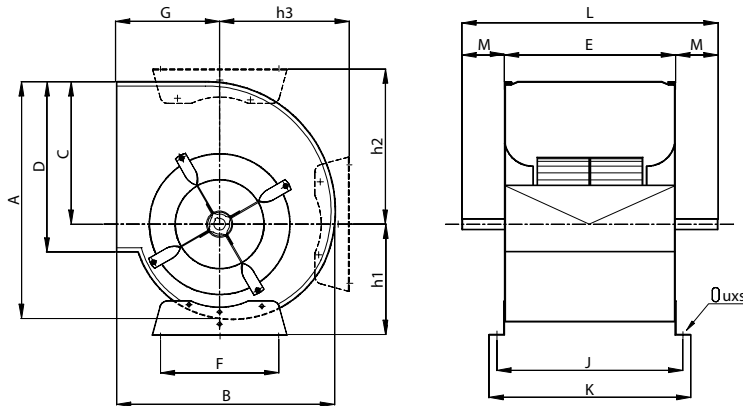

Model	A	B	C	D	E	F	G	J	K	L	M	h1	h2	h3	ød		
															CL	CM	uxs
200	364	342	215	256	256	224	164	281	306	420	82	181	245	184	20	20	11x16
225	408	380	243	288	288	224	180	313	338	452	82	197	274	204	20	20	11x16
250	452	416	270	322	322	224	194	347	372	486	82	210	299	227	20	20	11x16
280	508	464	302	360	360	280	214	390	420	556	98	236	331	255	25	25	11x16

All Dimensions in mm.

BDB 200-280 'C'

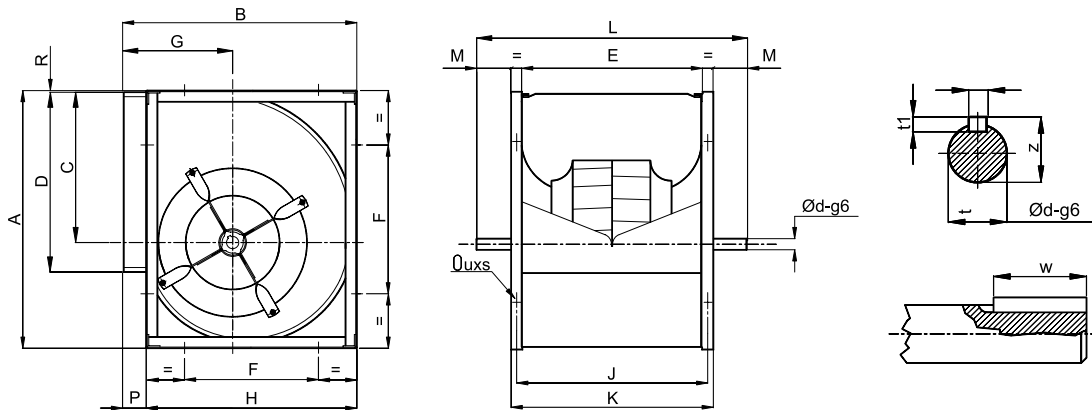

Model	A	B	C	D	E	F	G	H	J	K	L	M	P	R	t	t1	w	z	ød		
																			CL	CM	uxs
200	370	343	215	256	256	224	164	306	281	306	420	57	37	4	6	6	30	22.5	20	20	11x16
225	415	382	243	288	288	224	180	348	313	338	452	57	34	3	6	6	30	22.5	20	20	11x16
250	460	418	270	322	322	224	194	383	347	372	486	57	35	4	6	6	30	22.5	20	20	11x16
280	518	466	302	360	360	280	214	432	390	420	556	68	34	5	8	7	40	28	25	25	13x18

All Dimensions in mm.

BDB 250-280 'T'

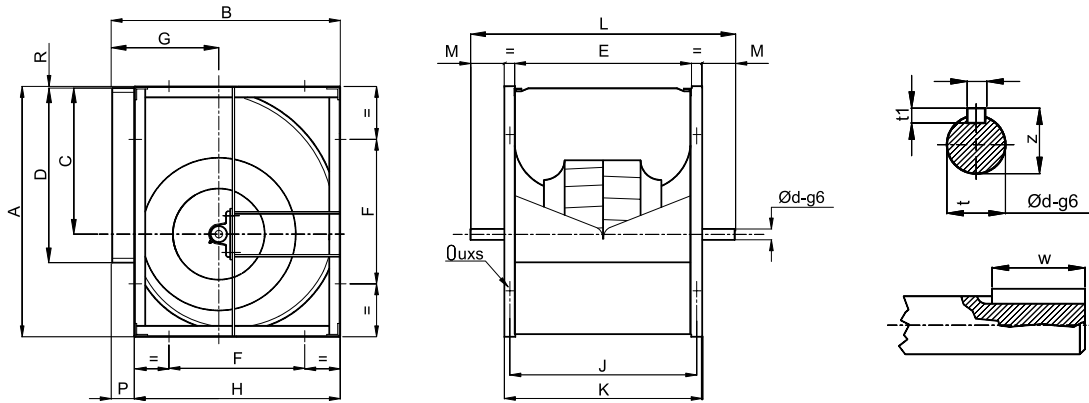

Model	A	B	C	D	E	F	G	H	J	K	L	M	P	R	t	t1	w	z	Ød		
																			TL	TM	uxs
250	460	418	270	322	322	224	194	383	347	372	538	83	35	4	8	7	40	28	25	25	11x16
280	518	466	302	360	360	280	214	432	390	420	588	84	34	5	8	7	40	33	30	30	13x18

All Dimensions in mm.

Shaft

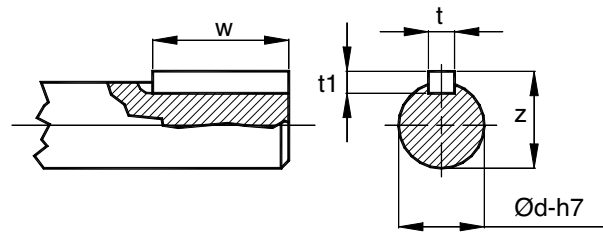

Ød	t	t1	w	z
20	6	6	30	22,5
25	8	7	40	28

All Dimensions in mm.

Operational Limits - "BDB"

			200	225	250	280
Maximum Absorbed Power	S-C	kW	2	2,2	2,5	2
	T	kW	-	-	6	7
Maximum Fan Speed	S-C	rpm	5200	4500	4000	3500
	T	rpm	-	-	5200	4600
Temperature Range Min. -20°C	S	Max.°C	85	85	85	85
	C	Max.°C	85	85	85	85
	T	Max.°C	-	-	100	100
Fan weight	S	kg	8	10	11	17
	C	kg	9,5	11,5	14	20
	T	kg	-	-	20	27



Research
Design and
High Technology



Soler & Palau

Sales Department

C/ Llevant, 4 – Polígono Industrial Llevant
08150 Parets del Vallès (Barcelona) - SPAIN
Tel. +34935719420
Fax +34935719421
e-mail: oem.info@solerpalau.com
Web: <http://www.solerpalau.com>