

A (mm)	B (mm)
35	60
45	60
45	75
70	100

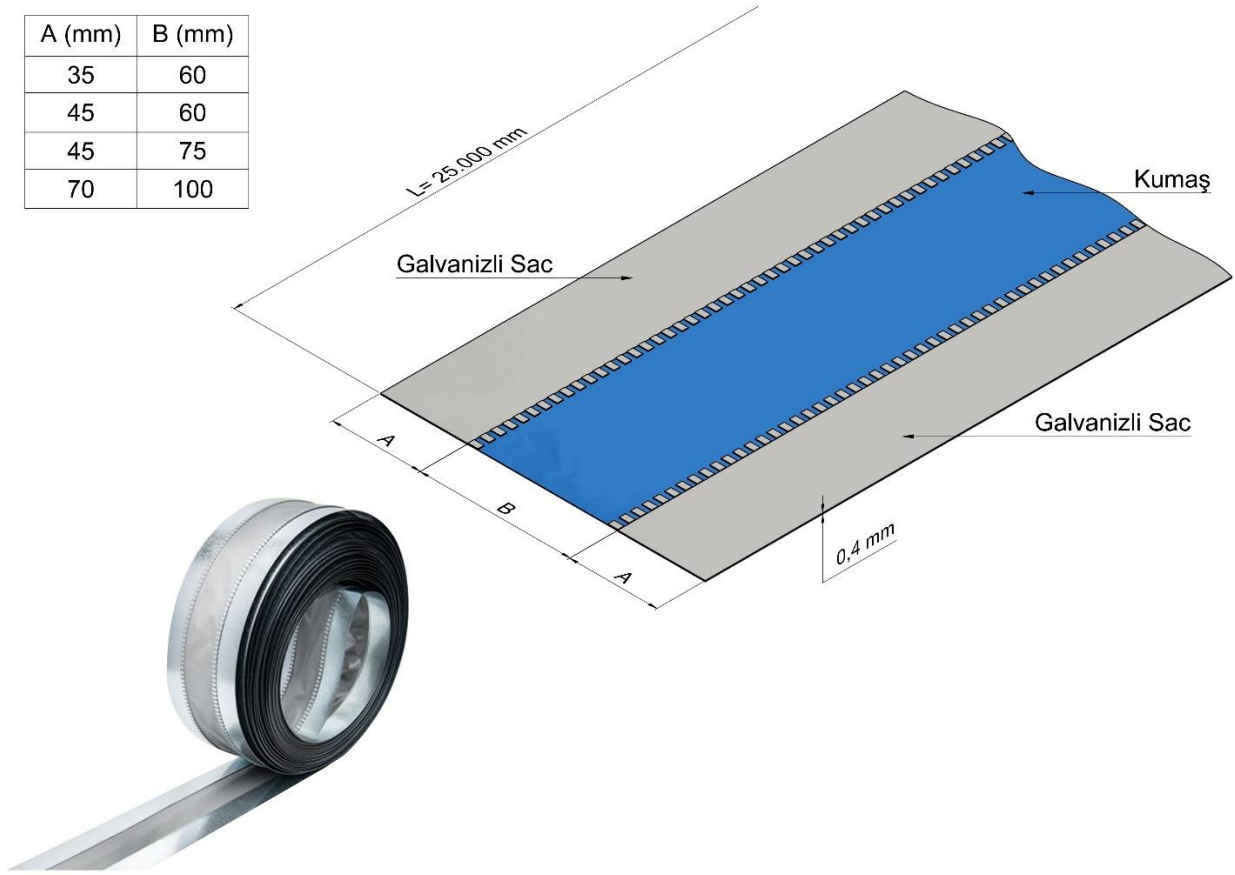

## **PVC FLEXIBLE DUCT CONNECTOR**

### **FLEXIBLE DUCT CONNECTOR**

In order to isolate vibrations caused by air handling units, fans or other equipments connected to air ducts, it is recommended to install a flexible duct connector.

- Reinforced PVC used between two galvanized sheets (0,40 mm. thickness) has been combined with multi-lock system and it is inseparable.
- Airtight.
- Can easily be applied to corners, square, oval and round joints.
- It is produced accordance to ISO 9001:2008
- GOST-R certificated
- Standard Length is 25 M

• **TECHNICAL SPECIFICATIONS**

<b>FABRIC</b>	<b>MATERIAL / SPECIFICATION</b>
Backing	Polyester
Coating	PVC (Both sides)
Colour	Gray
Total Weight	600 gr/m <sup>2</sup>
Total Thickness	420 microns
Tensile Strength	980 x 850 N
Fire Resistance	Fire Retardant
Temperatures	-30 ° C +80 ° C
Use	Very good mechanical resistance, economical

**TDS NO: 35    Date: 04.03.2010**

**Rev. No: ---    Rev. Date: ---**

**All rights are reserved.**

**İŞİL MÜH. MAK. Ve İNŞ. SAN. TİC. A.Ş.**