

# AV-TTW6

Single Room Heat Recovery Ventilator  
Instruction Manual

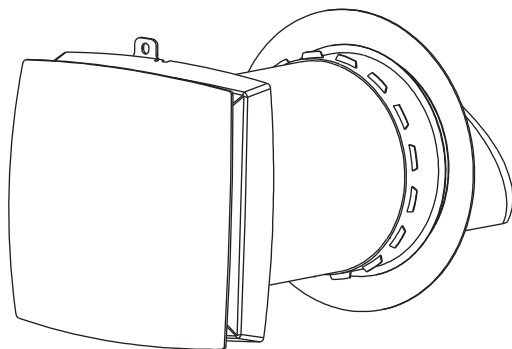

CE

# Content

SAFETY REQUIREMENTS .....	3
INTRODUCTION .....	6
USE .....	6
PACKING LIST .....	6
MAIN TECHNICAL PARAMETERS .....	7
DESIGN AND OPERATION .....	9
INSTALLATION AND SET-UP .....	11
CONNECTION TO POWER .....	13
VENTILATOR CONTROL .....	14
MAINTENANCE .....	15
TROUBLES HOOTING .....	17
STORAGE AND TRANSPORTATION RULES .....	18

## SAFTY REQUIREMENTS

- Read the user's manual carefully before the operation and installation of the heat recovery ventilator AV-TTW6
- Installation and operation of the ventilator shall be performed in accordance with the present user's manual as well as the provisions of all the applicable local and national construction, electrical and technical codes and standards.
- The warnings contained in the present user's manual must be considered seriously since they contain vital personal safety information.
- Failure to follow the safety regulations may result in an injury or ventilator damage.
- Read the manual carefully and keep it as long as you use the ventilator.
- This appliance can be used by children aged from 8 years and above and persons with reduced physical, sensory or mental capabilities or lack of experience and knowledge if they have been given supervision or instruction concerning use of the appliance in a safe way and understand the hazards involved.
- Children shall not play with the appliance.
- Cleaning and user maintenance shall not be made by children without supervision.
- If the supply cord is damaged, it must be replaced by the manufacturer, its service agent or similarly qualified persons in order to avoid a hazard.
- That the fan is to be installed so that the blades are more than 2.1 m above the floor (for fans intended to be mounted at high level);
- That precautions must be taken to avoid the back-flow of gases into the room from the open flue of gas or other fuel-burning appliances (for duct and partition fans).

# Instruction Manual for the user and the qualified installer

- Exhaust fans may adversely affect the safe operation of appliances burning gas or other fuels (including those in other rooms) due to back flow of combustion gases. These gases can potentially result in carbon monoxide poisoning. After installation of an exhaust fan such as a partition fan or a duct fan the operation of open flued gas appliances should be tested by a competent person to ensure that back flow of combustion gases does not occur.
- Non-rechargeable batteries are not to be recharged
- Batteries are to be inserted with the correct polarity
- Exhausted batteries are to be removed from the appliance and safely disposed of
- If the appliance is to be stored unused for a long period, the batteries should be removed
- The supply terminals are not to be short-circuited

## SYMBOL USED IN THE MANUAL:



**WARNING!**



**DO NOT!**

## VENTILATOR INSTALLATION SAFETY PRECAUTIONS



The ventilator must be disconnected from the power supply prior to the installation or repair operation.



The ventilator must not be operated outside the temperature range stated in the user's manual or in aggressive or explosive environment.



Do not position any heating devices or other equipment in close proximity to the ventilator power cord.

# Instruction Manual for the user and the qualified installer



Do not use damaged equipment or conductors to connect the ventilator to power.

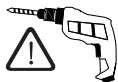

While installing the ventilator, follow the safety regulations specific to the use of electric tools.



Unpack the ventilator with care.



Use the ventilator only as intended by the manufacturer.

## VENTILATOR INSTALLATION SAFETY PRECAUTIONS



Do not touch the controller or the remote control with wet hands. Do not carry out the ventilator maintenance with wet hands.



Do not let children operate the ventilator.



Do not wash the ventilator with water. Protect the ventilator electric parts from water ingress.



Do not block the air duct when the ventilator is on.



Disconnect the ventilator from power supply before maintenance.



Do not damage the power cable while operating the ventilator. Do not put any objects on the power cable.

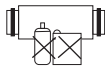

Keep explosive and inflammable products away from the ventilator.



Do not open the operating ventilator.



Do not let air flow from the ventilator be directed to the open flame devices or candles.

# Instruction Manual for the user and the qualified installer

## INTRODUCTION

This user's manual includes technical description operation, installation and mounting guidelines, technical data for the heat recovery ventilator AV-TTW6.

## USE

- The ventilator is designed to arrange permanent controllable air exchange in apartments, villas, hotels, cafes and other domestic and public buildings. The ventilator is equipped with a ceramic heat exchanger that enables supply of fresh air and extract air with heat energy recovery.
- The ventilator is designed for through-the-wall mounting. The telescopic ventilator design enables its installation in the walls from 230 mm to 420mm thickness for the ventilator AV-TTW6.
- The ventilator is rated for continuous operation always connected to power mains.
- Transported air must not contain any flammable or explosive mixtures, evaporation of chemicals, coarse dust, soot and oil particles, sticky substances, fibrous materials, pathogens or any other harmful substances.



**INSTALLATION AND CONNECTION OPERATIONS MUST BE PERFORMED ONLY BY PROPERLY QUALIFIED PERSONNEL AFTER THE APPROPRIATE SAFETY BRIEFING.**

**THE VENTILATOR INSTALLATION SITES MUST PREVENT ACCESS BY UNATTENDED CHILDREN.**

## PACKING LIST

Ventilator	1
Accessories bag	1
Remote controller	1
User's manual	1
Packing box	1

## MAIN TECHNICAL PARAMETERS

- The ventilator is designed for indoor application with the ambient temperature ranging from  $-20^{\circ}\text{C}$  ( $-4^{\circ}\text{F}$ ) to  $+50^{\circ}\text{C}$  ( $+122^{\circ}\text{F}$ ) and relative humidity below 80%.
- The ventilator is classified as a class I electric appliance.
- Ingress Protection (IP) rating from solid objects and liquids IP22.
- The ventilator design is regularly improved, so some models may slightly differ from those ones described in this manual.

## VENTILATOR OVERALL DIMENSIONS (MM)

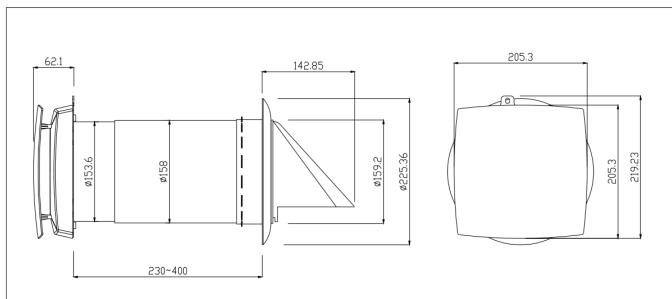

# Instruction Manual for the user and the qualified installer

Voltage	220-240 V
Frequency	50/60 Hz
Input Power	12 W
Current	0.08 A
RPM	2000 (max)
Airflow (L/M/H)	20/42/64 m <sup>3</sup> h
Noise	36.7 dB(A)
Regeneration Efficiency	up to 92%
Ingress Protection Rating	IP22
Air Duct	158 mm
SEC	Class A
Mounting	Wall Mounting
Net Weight	3.4kg



## DESIGN AND OPERATION

The ventilator consists of the telescopic air duct with adjustable length regulated by position of the inner air duct inside the outer air duct, the ventilation unit and the ventilation hood.

Two filters and the ceramic core are located inside the inner duct. The filters are designed to purify supply air and prevent foreign object ingress to the heat exchanger and the fan.

The ceramic heat exchanger extracts energy from exhaust air to warm up or cool down supply air.

The heat exchanger is equipped with a pull cord inside to facilitate its withdrawal from the ventilator. The heat exchanger is installed on an insulation material which used as a sealant as well.

The fan must be installed on inner side of the wall.

The ventilation hood must be installed on outer side of the wall to prevent ingress of water and other objects to the ventilator.

## INSTALLATION DRAWING

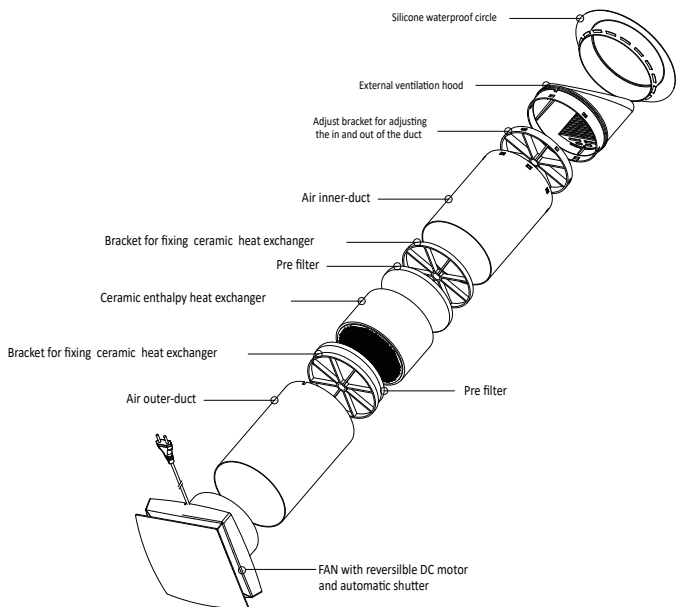

# Instruction Manual for the user and the qualified installer

## OPERATION MODES

**Ventilation Mode.** The ventilator runs in the air extract or air supply mode with a set speed. In case of synchronous operation of two connected ventilators one unit operates in the supply mode and the other one in the extract mode.

**Regeneration Mode.** The ventilator runs in two cycles, 75 seconds of each, to provide heat and moisture regeneration.

**Interval 1** The warm polluted air is extracted from the room and goes through the ceramic regenerator, which gradually absorbs heat and moisture. After 75 seconds the ventilator switch to supply air mode.

**Interval 2** The fresh and cold outdoor air goes through the heat regenerator and absorbs the accumulated moisture and heat after 75 seconds, when the energy regenerator gets cold, the ventilator switches to the air extract mode.

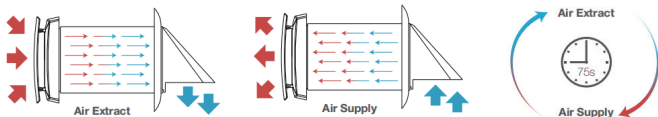

## INSTALLATION AND SET-UP



**CAUTION!**

**READ THE USER'S MANUAL BEFORE INSTALLATION THE VENTILATOR**

The ventilator must not be installed in sites where the air duct may be clogged by the blinds, curtains, drapes, etc, to prevent the room dust deposition and accumulation, also, curtains might obstruct normal airflow in the room, thus rendering ventilator operation not efficient.

# Instruction Manual for the user and the qualified installer

## VENTILATOR INSTALLATION

1. Prepare a round hole through in the inner wall . The hole size is shown below.

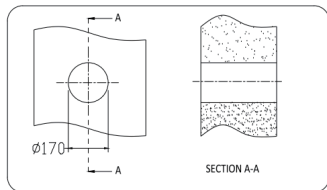

2. Assemble inner duct and outer duct together to adapt to the thickness of wall. Then take out the inner duct. Handle the bracket to turn the outer duct forward and backward, left and right to make the air inlet/outlet installed downward correctly by the sign of the external ventilation hood.

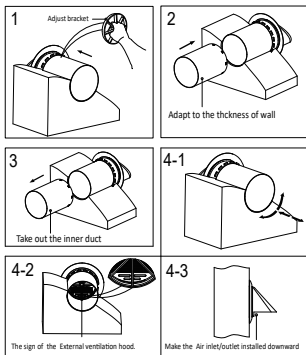

3. Install the ventilator through the wall hole from indoor, and pull back the duct by the adjust bracket to make the inner side rubber ring cling to the outside wall. Then put the inner duct in the hole and assembly inner duct and outer duct together. Fill the gap between the wall and duct with PU foam (Using waterproof sealing glue for the gap close to indoor to against rainwater). The inner duct should parallel with indoor wall surface.

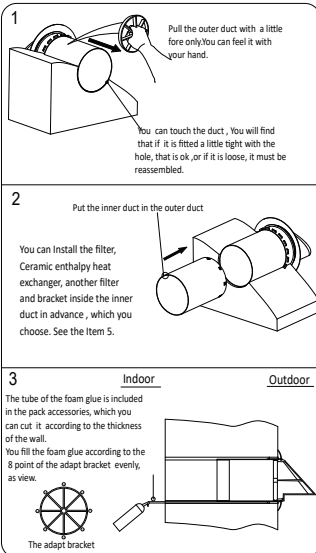

# Instruction Manual for the user and the qualified installer

4. Put the fan on the surface wall as the location, which the bracket and the nut are installed on the fan in advance , that the duct of the fan must be into the inner duct. Marking the drilling hole site. After put the fan out Drilling 1\*6mm hole on the marking place and put in the rubber plug(as pack accessories) .Install the retaining bracket with a screw(as pack accessories)

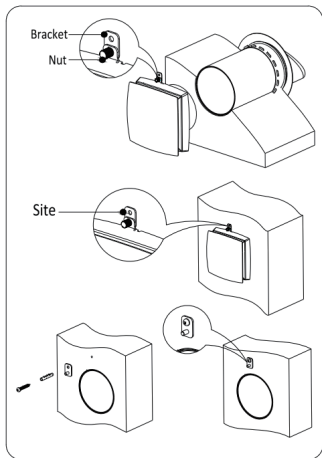

5. Install the filter, ceramic enthalpy heat exchanger, another filter and bracket inside the inner duct. In this item , carry out the step in advance in the item 3, which you have put the fittings in the inner duct.

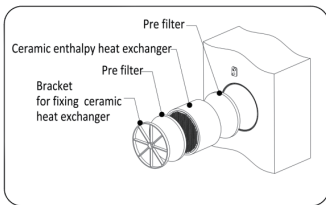

6.Install the fan on the surface wall. The fan is fixed with nut.

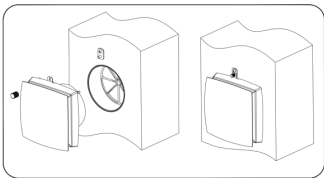

7. If you install the ventilator in the absence of rain , you can attach the rubber ring of the accessories bag from outer duct with the silicone glue. Don't fill the gap between the wall and duct with PU foam.

## CONNECTION TO POWER



DISCONNECT THE VENTILATION FROM POWER MAINS TO ANY ELECTRIC INSTALLATION OPERATIONS.

The ventilator is rated for connection to single-phase AC220-240 V/50-60 Hz power mains. Connect the ventilator to the socket directly.

# Instruction Manual for the user and the qualified installer

## FUNCTION DESCRIPTION

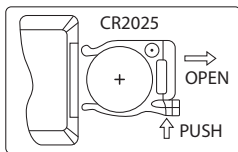
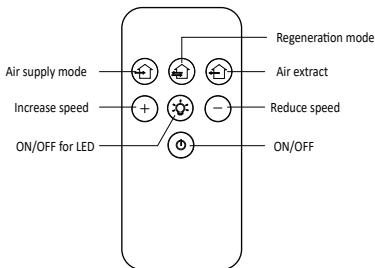
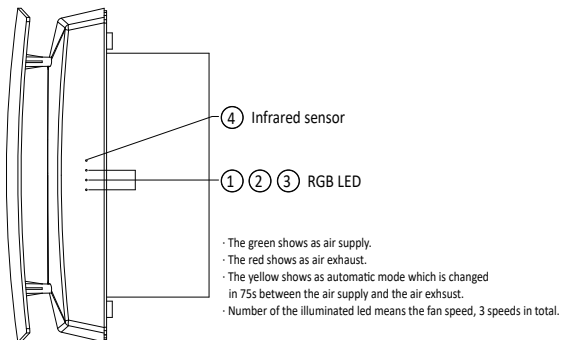

- Remove the insulating plastic membrane of the battery before using the remote control.
- Battery specifications: CR2025.
- Operate as shown below if replace the battery.

## MAINTENANCE



DISCONNECT THE VENTILATOR FROM POWER SUPPLY PRIOR TO ANY MAINTENANCE OPERATIONS.

Maintenance of the ventilator means regular cleaning of the ventilator surfaces of dust and cleaning or replacement of the filters.

### 1. Fan maintenance (once per year).

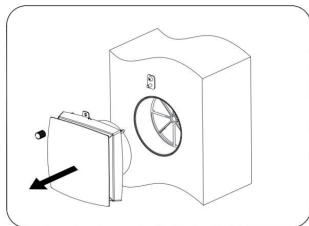

Loose the nut and pull the ventilator to remove.

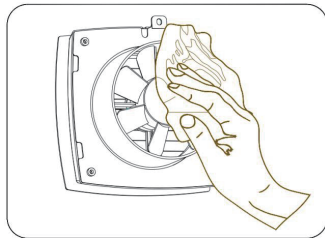

Clean the impeller blades. Use a soft brush, doth or a vacuum cleaner to clean the impeller. Do not use water abrasive detergents, solvents, sharp objects. The impeller blades must be cleaned once in year.

### 2. Regenerator and filter maintenance (4 times per year).

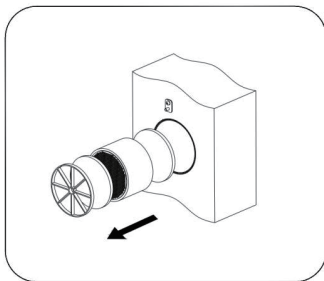

Remove the air flow rectifier and the filter in front of the regenerator.

Pull the exchanger cord to remove heat exchanger from the air duct.

Be careful while pulling the Exchanger to avoid damage.

Remove the filter after the exchanger.



Clean the filter as often as it gets dirty, but at least 3-4 times a year. Clean the filters, let them get dry and install the dry filters inside the air duct Vacuum cleaning is allowed. The filter rated service life is 3 years. Contact the Seller for spare filters.



Even regular technical maintenance may not completely prevent dirt accumulation on the regenerator assemblies.

Subject the exchanger to regular cleaning to ensure high heat exchange efficiency.

Clean the exchanger with a vacuum cleaner at least once in a year.



## TROUBLESHOOTING

Possible faults and troubleshooting

<b>Fault</b>	<b>Possible reasons</b>	<b>Fault handling</b>
The fan does not start up during the ventilator start-up.	No power supply.	Make sure that the ventilator properly connected to the power and make any corrections, if necessary.
	Motor is jammed, the impellers are clogged.	Turn the ventilator off. Troubleshoot the motor jam and the impeller dogging. Clean the blades. Restart the ventilator.
Low air flow.	Low setting fan speed.	Set higher speed.
	The filter, the fan or the exchanger are dirty.	Clean or replace the filter, clean the fan and the exchanger. For the exchanger and the filter maintenance, refer to page 14.
Noise, vibration.	The impeller is dirty.	Clean the impeller.
	Loose screw Connection of the ventilator casing or the ventilation hood.	Tighten the screws of the ventilator or the outer ventilation hood.

## STORAGE AND TRANSPORTATION RULES

Store the ventilator in the manufacturers original packing box in a dry place.

Storage environment must not contain aggressive vapours and chemical mixtures provoking corrosion, insulation and sealing deformation .Use hoist machinery for handling and storage operations to prevent the ventilator damage in consequence of failing or excessive oscillation. Fulfil the handling requirements applicable for the applicable freight type.

Transportation with any vehicle type is allowed provided that the ventilator is protected against mechanical and weather damage.

Avoid any mechanical shocks and strokes during handling operations.

# **Instruction Manual** for the user and the qualified installer