

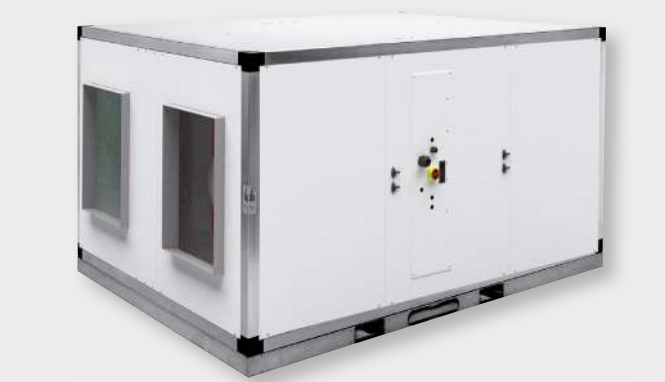

# CADB/T-HE ECOWATT





## INDEX

1. INTRODUCTION .....	4
2. SAFETY REGULATIONS AND "CE" MARKING .....	4
3. GENERAL INSTRUCTIONS .....	4
4. UNIT LABELLING .....	4
5. HANDLING .....	5
6. INSTALLATION.....	6
6.1. Introduction.....	6
6.1.1. Outdoor installation.....	10
6.2. Dimensions and free space for maintenance .....	11
6.3. Mounting process of an additional supply filter .....	13
6.4. Range specifications.....	14
6.5. Connections .....	15
6.5.1. Connection with air duct .....	15
6.5.2. Connecting the water coil piping. DC versions .....	15
6.5.3. Condensate drainage .....	16
6.6. Electrical connection .....	16
6.6.1. Connecting the motors.....	16
6.6.2. Connecting the By-pass .....	20
6.6.3. Connecting the electric batteries.....	21
6.6.4. Connecting electrical accessories .....	26
6.6.4.1. Manual VAV control (variable airflow) .....	27
6.6.4.1.1. 04 to 27 models: Manual adjustment by REB-ECOWATT (accessory) .....	27
6.6.4.1.2. 33 to 100 models: Manual adjustment by REB-ECOWATT (accessory) .....	28
6.6.4.2. VAV Control (variable airflow), with CO <sub>2</sub> sensor or similar .....	29
6.6.4.3. CAV control (Constant airflow) .....	29
6.6.4.4. COP Control (Constant pressure).....	31
6.6.4.5. Pressure switch connection .....	32
6.7. Reverse supply air/extract air side (only -D version).....	33
6.8. Configurations .....	34
6.9. Control of cooling external batteries .....	36
6.9.1. Accessories assembly .....	37
6.9.2. Coils characteristics.....	41
6.9.2.1. Cold water coils for 2 pipes installation.....	41
6.9.2.2. Cold water coils for for 4 pipes installation .....	41
6.9.2.3. Expansion coils for integration in DX systems.....	42
7. INSPECTION, MAINTENANCE AND CLEANING.....	42
7.1. Filters.....	42
7.2. Filter installation .....	44
7.3. Heat exchanger.....	45
7.4. Condensation drainpipe.....	46
8. OPERATION ANOMALIES .....	47
8.1. General anomalies .....	47



## 1. INTRODUCTION

---

Thank you for purchasing this appliance. It has been manufactured in full compliance with applicable safety regulations and EU standards.

Please read this instruction book carefully, as it contains important information for your safety during the installation, use and maintenance of this product.

Keep it at hand for future reference.

Please check that the appliance is in perfect condition when you unpack it, as all factory defects are covered by the **S&P** guarantee.

## 2. SAFETY REGULATIONS AND “CE” MARKING

---

**S&P** technicians are firmly committed to research and development of ever more efficient products and in compliance with current safety regulations.

The instructions and recommendations given below reflect current regulations, principally regarding safety, and therefore are based on compliance with general regulations. Therefore, we recommend all people exposed to hazards to strictly follow the safety regulations in force in your country.

**S&P** will not be held liable for any possible harm or damage caused by non-compliance with the safety regulations, as well as caused by modifying the product.

The **CE** mark and the corresponding declaration of conformity are proof of the product’s conformity with current EU regulations.

## 3. GENERAL INSTRUCTIONS

---

A hazard analysis of the product has been carried out as provided in the Machine Directive. This manual contains information for all personnel exposed to these hazards, with the aim of preventing possible harm or damage due to faulty handling or maintenance.

All maintenance operations (ordinary and extraordinary) must be carried out with the machine switched off and the electrical power supply disconnected.

To avoid a possible accidental start up, place a warning notice on the electrical control panel with the following text:

**“Attention: control disconnected for maintenance operations”**

Before connecting the power supply cable to the terminal strip, make sure the mains voltage corresponds to the voltage indicated on the specifications plate of the unit.

Regularly check the product labels. If, due to the passing of time, they are no longer legible, they must be replaced.

## 4. UNIT LABELLING

---

The machine may come with several pictograms that must not be removed. These signs are divided into:

- **Prohibition signs:** Do not repair or adjust when in operation.
- **Danger signs:** Warning of the presence of live elements inside the container bearing the sign.
- **Identification signs:** CE card, indicating product information and manufacturer’s address. The CE mark indicates the product’s conformity with EEC standards.



Danger signs



Prohibition signs

## 5. HANDLING

---

The CADB/T-HE models 04 to 33 are delivered fixed with screws to the pallets.

The models 45 to 100 are equipped with a bed, due to its weight are supplied without pallets. The unit can be handled by a pallet transporter, a forklift, or a crane.

The handling machines will be adapted to the load and the lifting conditions. In all cases, the lifting will be done at the device's base. The centre of gravity is located at the centre of the unit. The device must be carefully manipulated only in the horizontal position.

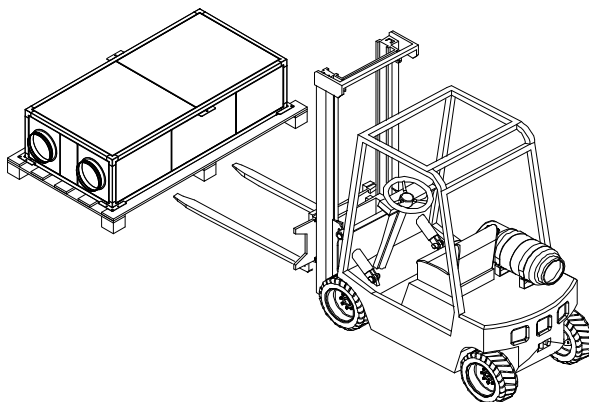

Models 04 to 33

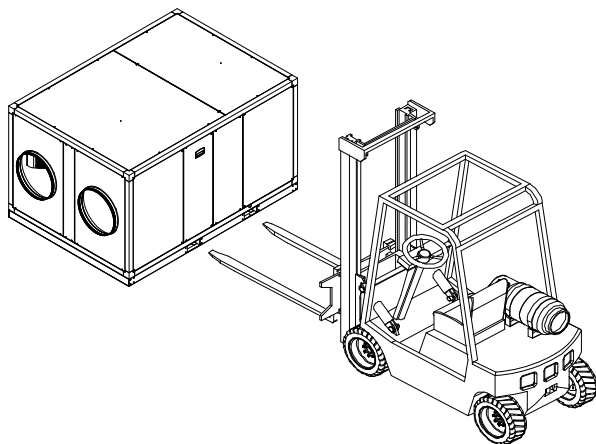

Models 45 to 100

## 6. INSTALLATION

### 6.1. INTRODUCTION

#### Horizontal models size 04, 08, 12, 16, 21, 27 and 33

These models are designed to be installed hanging from the ceiling or located behind a false ceiling. When installing the unit, it is mandatory to distribute the unit weight between all the supports existing in the units:

- CADB-HE 04: 4 supports (one in each corner)
- CADB/T-HE 08 to 33: 6 supports (one in each corner and 2 centered in each side)

Using studded rods ( $\varnothing$  8 mm), it can be secured to the ceiling and levelled.

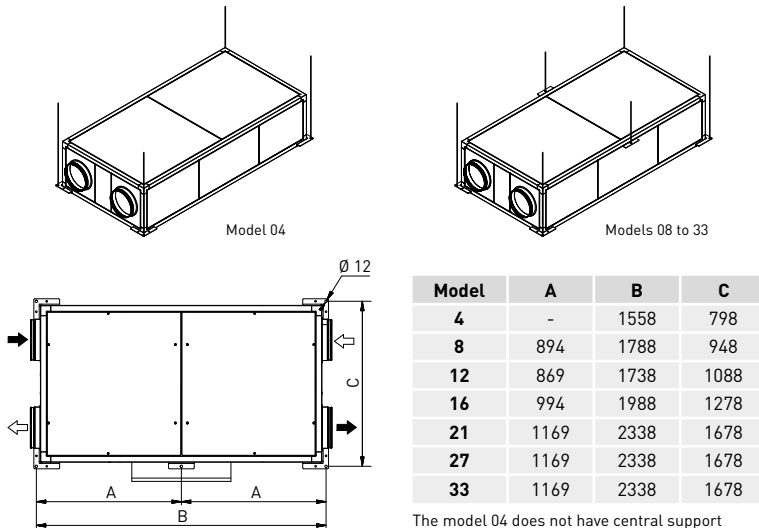

The model 04 does not have central support

The installer must make sure that the ceiling structure and the securing elements can bear the weight of the device, taking into account that it is a dynamic load.

To prevent the transmission of vibrations from the unit to the rest of the installation, it is necessary that the installer use specific isolation elements, such as antivibration devices in the supports, flexible sleeves between the unit and the ducts, and flexible couplings between the water connections and the pipelines.

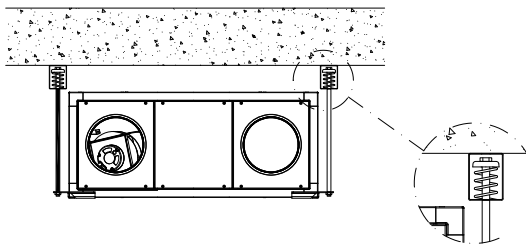

Model	Weight (kg)
4	137
8	173
12	180
16	225
21	323
27	360
33	410

## Vertical models

The models size 4 to 33 are supplied with support feet, while the models size 45 to 100 are supplied with a perimetral bed. This bed must be in contact with the ground or with a fl at surface. It is essential that the weight of the equipment is distributed between all points of support to prevent unit deformation.

**The installer must make sure that the ceiling structure and the securing elements can bear the weight of the unit, taking into account that it is a dynamic load.**

### Models 04 to 33

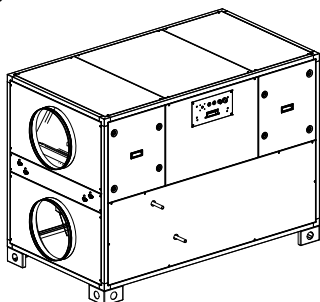

Model	Weight (kg)
4	139
8	175
12	182
16	227
21	325
33	412

### Models 45, 60 and 100

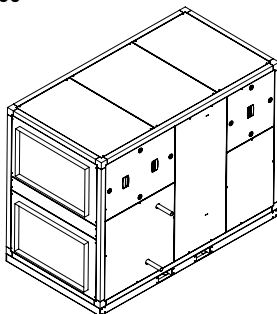

Model	Weight (kg)
45	577
60	710
100	842

### Horizontal models of sizes 45 and 60

## IMPORTANT!

### Particularities in the installation of horizontal versions LH and RH

For a correct evacuation of condensation generated into the heat exchanger, it is necessary to install the unit with a minimum slope of 3° to the side where the extraction fan is placed:

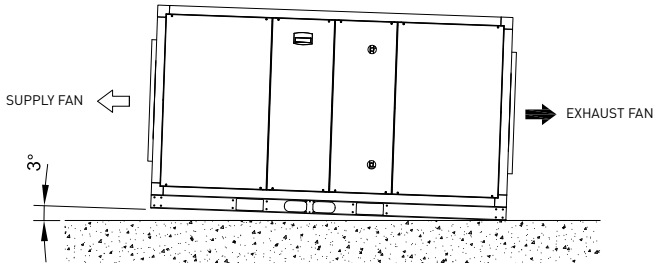

Horizontal models size 45 and 60 are supplied with a perimetral bed. This bed must be in contact with the ground or with a flat surface. It is essential that the weight of the equipment is distributed between all points of support to prevent unit deformation.

**The installer must make sure that the ceiling structure and the securing elements can bear the weight of the unit, taking into account that it is a dynamic load.**

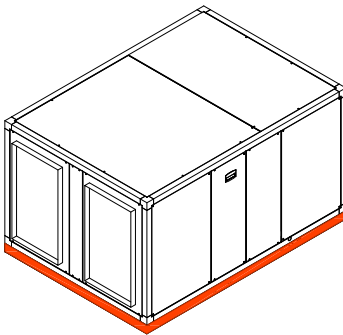

Model	Weight (kg)
45	577
60	710

### For all configurations

Once secured the device in correct position, the installer have to realise the connection with air duct, connection to the electric supply, and in the case of versions with water coil, the connection with closed circuit of hot water coil.

Inside of the unit are supplied the following accessories:

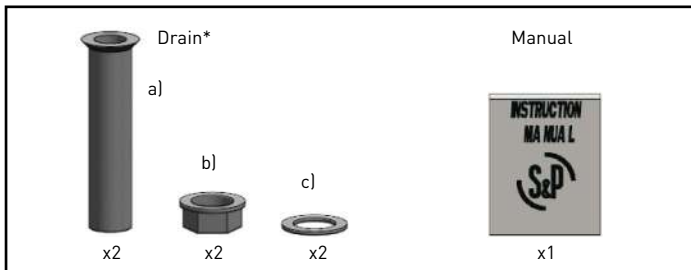

\* In the models 45 and 60 the drain is installed by default in the unit.



The drain is composed by 3 pieces:

- a) Drainpipe
- b) Female screw
- c) Joint ring

**a) Horizontal versions of CADB/T HE 04 to 33**

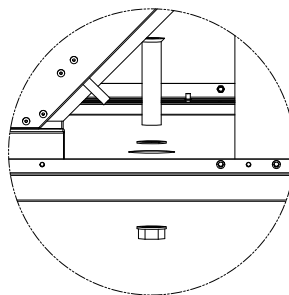
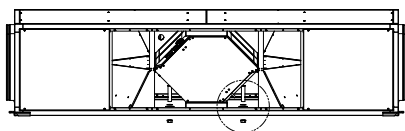

**b) Horizontal versions of CADB/T HE 45 and 60**

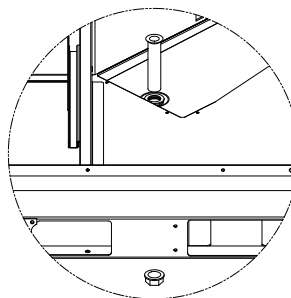
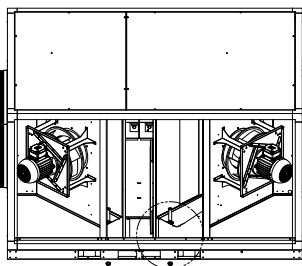

**c) Vertical versions of CADB/T HE 04 to 33**

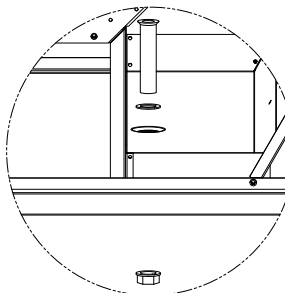
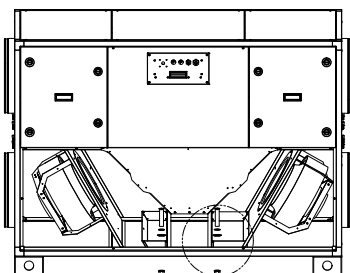



## d) Vertical versions of CADB/T HE 45, 60 and 100

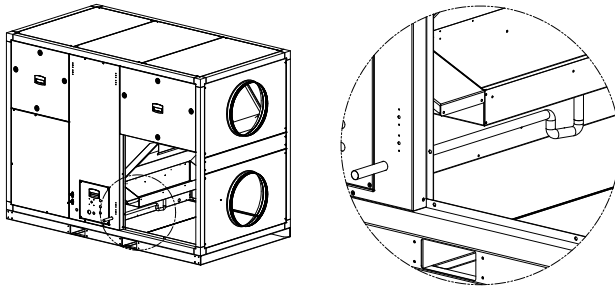

In these versions, the drainpipe and the siphon are supplied mounted in the unit.

### 6.1.1. Outdoor installation

Whenever possible, it is advisable to be mounted indoors. When it is installed outdoors, it is preferable to place the unit under a cover which offers enough protection to prevent rain falling directly to the unit, or install the corresponding rain canopy (TPP accessory). Due to its design and the position of its registers, it is preferable to use vertical versions (LV / RV) for outdoor installation. In addition, these versions have feet that allow direct placement on the ground. In horizontal version, models 04 to 33, ensure the sufficient space below the unit, to install a siphons in the drain pipe. If installed on the ground, sufficient space must be guaranteed under the unit so that it is possible to install the corresponding siphons in the condensate outlets of the unit.

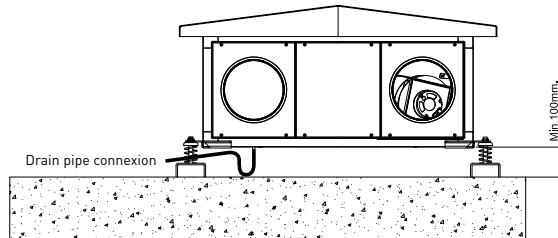

### Connected to the condensate line

There is a Kit composed of 6 feet, which facilitates the assembly on floor of these versions: 5407067200 - KIT PIES CADB-HE

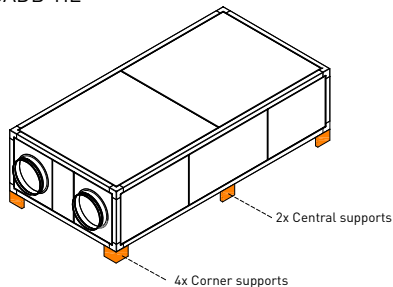

Detail of a CADB-HE 04 to 33 after the assembly of the KIT PIES CADB-HE

Both in the case that the Kit feet is used, and if the unit is based on vibrators or supports made on site, it is essential that the heat exchanger's support is guaranteed on the 6 existing support points and that all of them are in a same plane.

In the case of not supporting the unit on the central supports it is possible that deformation occurs in the structure of the unit, making it impossible to disassemble the panels.

Rain protection canopy available, according to the heat recovery unit model:

Heat recovery unit model	Rain protection cowl model	
	Horizontal (LH / RH)	Vertical (LV / RV)
CADB-HE D/DI/DC 04	TPP-HE-H 04	TPP-HE-V 04
CADB-HE D/DI/DC 08	TPP-HE-H 08	TPP-HE-V 08
CADB-HE D/DI/DC 12	TPP-HE-H 12	TPP-HE-V 12
CADB-HE D/DI/DC 16	TPP-HE-H 16	TPP-HE-V 16
CADB/T-HE D/DI/DC 21	TPP-HE-H 21/27/33	TPP-HE-V 21/27
CADB/T-HE D/DI/DC 27	TPP-HE-H 21/27/33	TPP-HE-V 21/27
CADT-HE D/DI/DC 33	TPP-HE-H 21/27/33	TPP-HE-V 33
CADT-HE D/DI/DC 45	TPP-HE-H 45	TPP-HE-V 45
CADT-HE D/DI/DC 60	TPP-HE-H 60	TPP-HE-V 60
CADT-HE D/DI/DC 100	-	TPP-HE-V 100

### Avoid condensations in electrical cabinet

In units located in outdoor installation where the heat recovery units stop during the night or during long intervals of time, it is necessary to:

- Install isolation dampers in air inlet and air outlet.
- Add anticondensation devices in the electrical cabinet as: cabinet heating elements that prevent condensation formation on cabinet surfaces and electronic components.

## 6.2. DIMENSIONS AND FREE SPACE FOR MAINTENANCE

### a) Horizontal versions of CADB/T HE 04 to 33 (False ceiling installation)

Distances for maintenance in installations with access by the lateral panels

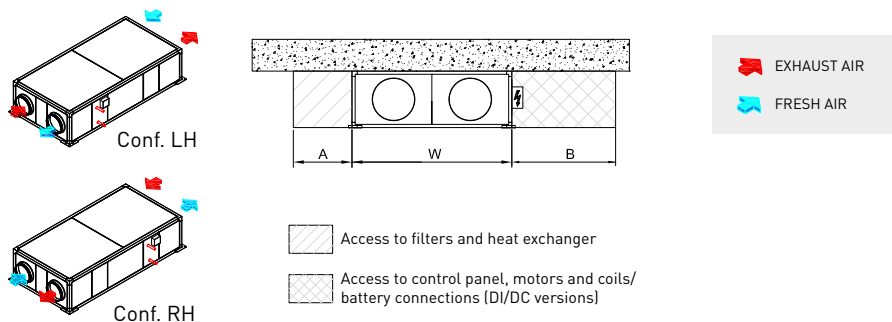

Distances for maintenance in installations with access by the inferior panels

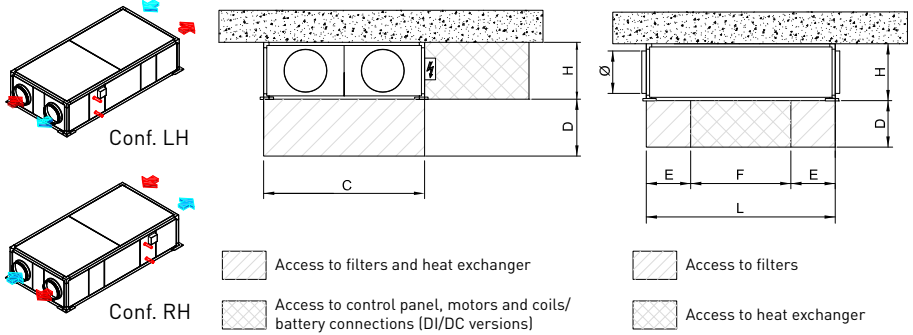

False ceiling installation

Model	W	H	L	A	B	C	D	Ø	E	F	Weight (kg)
04	760	375	1520	400	400	700	350	200	350	920	137
08	910	425	1750	450	400	860	400	250	400	950	173
12	1050	425	1700	500	400	1000	400	315	400	900	180
16	1240	450	1950	600	500	1190	425	315	400	1150	225
21/27	1640	550	2300	800	700	1590	525	400	500	1300	323
33	1640	650	2300	800	700	1590	325	400	500	1300	410

b) Horizontal versions of CADB/T HE 45 and 60 (Ground installation)

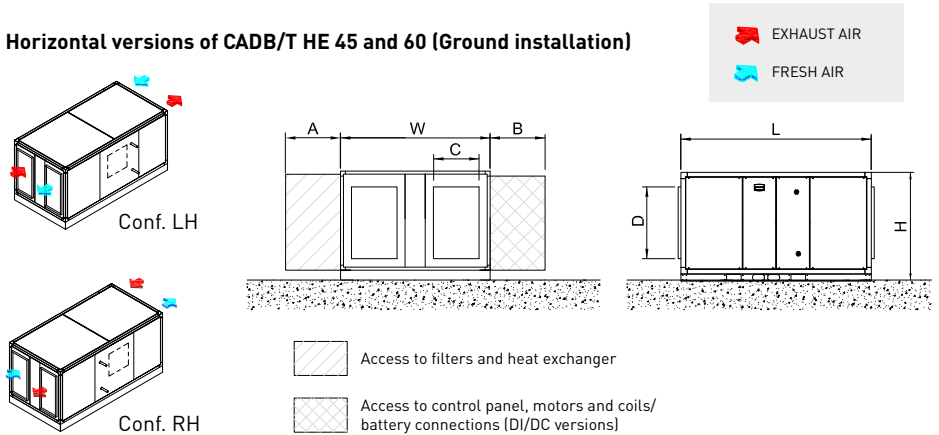

Ground installation

Model	W	H	L	A	B	C	D	Weight (kg)
45	1500	1200	2100	400	600	400	600	597
60	1550	1580	2250	400	750	500	700	730

### c) Vertical versions

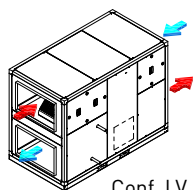

Conf. LV

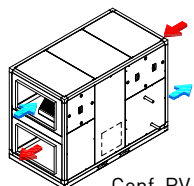

Conf. RV

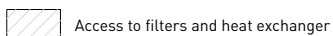
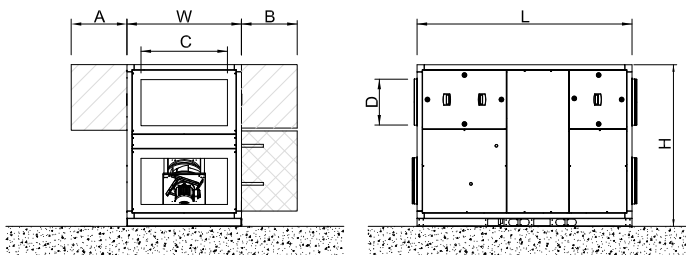

Access to filters and heat exchanger



Access to control panel, motors and coils/  
battery connections (DI/DC versions)

Model	W	H	L	A	B	Ø	C	D	Weight (kg)
4	540	920	1125	400	400	200	-	-	139
8	610	1020	1275	400	400	250	-	-	175
12	770	1020	1325	400	400	315	-	-	182
16	770	1070	1475	400	400	315	-	-	227
21	970	1270	1750	400	500	400	-	-	325
33	1170	1270	1750	400	500	400	-	-	412
45	1120	1580	2100	400	600	-	600	400	577
60	1500	1630	2250	400	800	-	700	500	710
100	2050	1630	2250	400	1000	-	1100	650	842

### 6.3. MOUNTING PROCESS OF AN ADDITIONAL SUPPLY FILTER

The heat recovery unit is supplied with the filters already installed. F7 (ePM1 70%) in exhaust air and M5 (ePM10 50%) in supply air. In addition, it is possible to mount a second filter in the unit (accessory) (for more information see section "Replacing filters").



## 6.4. RANGE SPECIFICATIONS

### D Versions: without heater battery

Model	Complete unit			Fan		
	Air connections diameter (mm)	Nominal airflow (m <sup>3</sup> /h)	Efficiency* (%)	Electrical supply	Speed (r.p.m.)	Maximum current (A)
CADB-HE D 04 ECOWATT	200	450	87	1/230V, 50Hz	3700	0,95
CADB-HE D 08 ECOWATT	250	800	86,4	1/230V, 50Hz	2650	1,3
CADB-HE D 12 ECOWATT	315	1.200	85,3	1/230V, 50Hz	2550	1,6
CADB-HE D 16 ECOWATT	315	1.600	85,5	1/230V, 50Hz	2845	2,0
CADB-HE D 21 ECOWATT	400	2.100	86,5	1/230V, 50Hz	1580	2,2
CADB-HE D 27 ECOWATT	400	2.700	83,8	1/230V, 50Hz	2450	3,6
CADT-HE D 33 ECOWATT	400	3.300	88,4	3/400V, 50Hz	2600	2,0
CADT-HE D 45 ECOWATT	400x600	4.500	88,9	3/400V, 50Hz	2200	3,0
CADT-HE D 60 ECOWATT	500x700	6.100	87,9	3/400V, 50Hz	2200	3,0
CADT-HE D 100 ECOWATT	1100x650	10.000	87,9	3+N/400V, 50Hz	2160	5,8

\* Wet efficiency referring to nominal airflow, outdoor conditions (-5°C / 80% RH) and indoor (20°C / 50% RH).

### DC Versions: with built-in hot water coil

Model	Complete unit			Fan			Hot water coil	
	Air connections diameter (mm)	Nominal airflow (m <sup>3</sup> /h)	Efficiency* (%)	Electrical supply	Speed (r.p.m.)	Maximum current (A)	Heat power T <sub>WATER</sub> 80/60°C (kW)	Heat power T <sub>WATER</sub> 50/45°C (kW)
CADB-HE DC 04 ECOWATT	200	450	87	1/230V, 50Hz	3700	0,95	2,7	1,6
CADB-HE DC 08 ECOWATT	250	800	86,4	1/230V, 50Hz	2650	1,3	5,1	3,1
CADB-HE DC 12 ECOWATT	315	1.200	85,3	1/230V, 50Hz	2550	1,6	7,1	4,3
CADB-HE DC 16 ECOWATT	315	1.600	85,5	1/230V, 50Hz	2845	2,0	8,6	5,3
CADB-HE DC 21 ECOWATT	400	2.100	86,5	1/230V, 50Hz	1580	2,2	12,6	7,8
CADB-HE DC 27 ECOWATT	400	2.700	83,8	1/230V, 50Hz	2450	3,6	16,2	10,0
CADT-HE DC 33 ECOWATT	400	3.300	88,4	3/400V, 50Hz	2600	2,0	18,2	11,1
CADT-HE DC 45 ECOWATT	400x600	4.500	89,0	3/400V, 50Hz	2200	3,0	25,6	15,5
CADT-HE DC 60 ECOWATT	500x700	6.100	88,9	3/400V, 50Hz	2200	3,0	34,7	21,1
CADT-HE DC 100 ECOWATT	1100x650	10.000	87,9	3+N/400V, 50Hz	2160	5,8	58,9	35,4

\* Wet efficiency referring to nominal airflow, outdoor conditions (-5°C / 80% RH) and indoor (20°C / 50% RH).

### DI Versions: with built-in electric battery

Model	Complete unit			Fan			Electrical heater battery		
	Air connections diameter (mm)	Nominal airflow (m <sup>3</sup> /h)	Efficiency* (%)	Electrical supply	Speed (r.p.m.)	Maximum current (A)	Electrical supply	Power (kW)	Maximum current (A)
CADB-HE DI 04 ECOWATT	200	450	87	1/230V, 50Hz	3700	0,95	1/230V, 50Hz	1	4,5
CADB-HE DI 08 ECOWATT	250	800	86,4	1/230V, 50Hz	2650	1,3	1/230V, 50Hz	2	9,1
CADB-HE DI 12 ECOWATT	315	1.200	85,3	1/230V, 50Hz	2550	1,6	1/230V, 50Hz	3	11,4
CADB-HE DI 16 ECOWATT	315	1.600	85,5	1/230V, 50Hz	2845	2,0	1/230V, 50Hz	3,5	15,9
CADT-HE DI 21 ECOWATT	400	2.100	86,5	1/230V, 50Hz	1580	2,2	3/400V, 50Hz	6	9,1
CADT-HE DI 27 ECOWATT	400	2.700	83,8	1/230V, 50Hz	2450	3,6	3/400V, 50Hz	6	9,1
CADT-HE DI 33 ECOWATT	400	3.300	88,4	3/400V, 50Hz	2600	2,0	3/400V, 50Hz	7,5	11,4
CADT-HE DI 45 ECOWATT	400x600	4.500	89,0	3/400V, 50Hz	2200	3,0	3/400V, 50Hz	9	13,7
CADT-HE DI 60 ECOWATT	500x700	6.100	88,9	3/400V, 50Hz	2200	3,0	3/400V, 50Hz	12	18,2
CADT-HE DI 100 ECOWATT	1100x650	10.000	87,9	3+N/400V, 50Hz	2160	5,8	3/400V, 50Hz	24	36,4

\* Wet efficiency referring to nominal airflow, outdoor conditions (-5°C / 80% RH) and indoor (20°C / 50% RH).

## 6.5. CONNECTIONS

### 6.5.1. Connection with air duct

The fans are always blowing out with regard to the machine. Before making the connection of air lines, verify existing identification labels in each mouth of the heat recovery units.

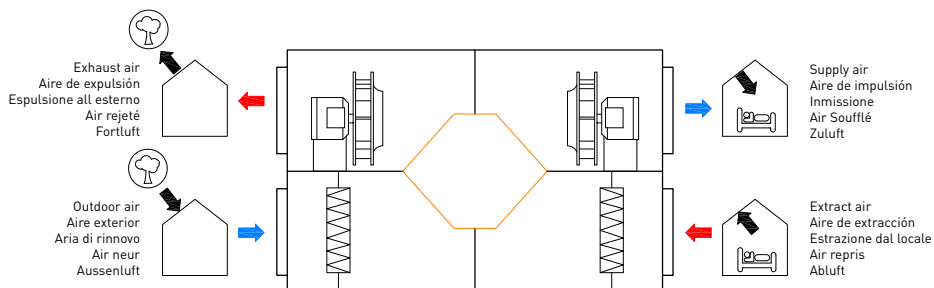

### 6.5.2. Connecting the water coil piping. DC Versions

Connecting the unit to the water network

- Maximum pressure: 31.62 bar
- Maximum temperature: 150°C

- Water coils of DC versions have threaded connections. Secure the coil manifold with the appropriate tool when tightening the threads. This will prevent the force from being transmitted to the manifold, which can damage it.

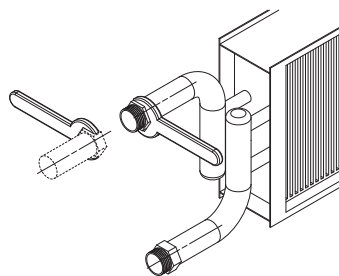

- The following table indicate the size and type o thread used on water coils for DC versions:

CADB/T-HE MODEL	THREAD
04, 08, 12, 16, 21, 27 and 33	1/2"
45, 60 and 100	1"

- To ensure the installation on a hand, it is essential that the installation includes the following elements:
  - Unit intake pre-filter that traps suspended particulate matter.
  - Bleed valves should be fitted at each of the high points in the installation.
  - Auto-filter valve to keep water in the hydraulic system at all times.
  - Pressure to detect the lack of water pressure.
  - Shut-off valves must be installed at each connection on the water line to allow the unit to be isolated if necessary (to clean filters, make repairs, replace parts, etc) and avoid the need to completely drain the water circuit.
  - Anti-vibration bellows should be installed at the inlet and outlet from the unit to prevent the transmission of vibrations that could result in damage to the heat exchanger coil due to excess stress on the circuits.

Once the installation is performed check that the heating water flow is adequate.



### 6.5.3. Condensate drainage

The units are supplied with 2 drains (one for each circuit). For added security it has to connect two drains to the condensate discharge pipe. This connection must be made through a pipe of 22 mm of inner diameter and a flange for secure fixation.

#### Drainage system

- To ensure the removal of draining condensate from the tray a siphon must be installed with pressure head difference in mmWG greater than the pressure provided by the fan.
- The horizontal sections should have a minimum slope of 2%.

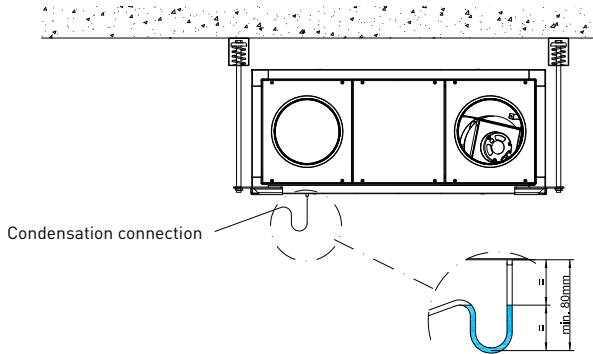

The siphon should always be full of water. Check its level periodically, refilling it if necessary. An empty siphon can cause the condensate tray to overflow and water leak through the equipment enclosure.

## 6.6. ELECTRICAL CONNECTIONS

The CADB/T-HE ECOWATT range are supplied without a complete operating control integrated in the unit, however the units include the electronic to control fan speed. The electrical components included in the unit are supplied wired in a terminal box or in a terminal board located inside the unit (depending on the version).

### 6.6.1. Connecting the motors

#### Horizontal versions CADB/T-HE 04 to 27 LH/RH

In these sizes the units have plug-fans with EC motors 230V supply voltage.

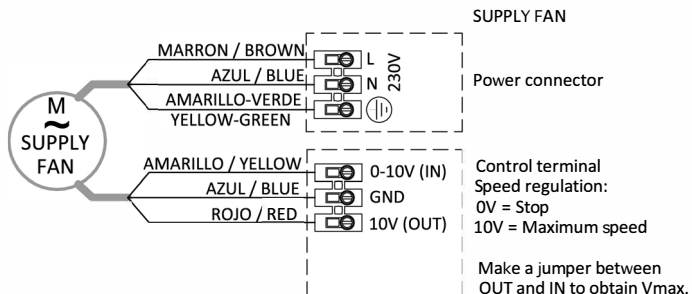



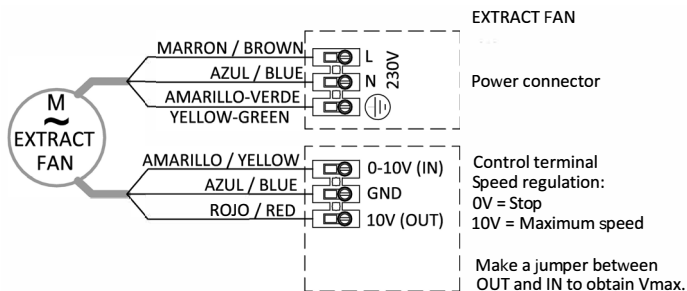

### Vertical versions CADB/T-HE 04 to 27 LV/RV

In these sizes the units have plug-fans with EC motors 230V supply voltage.

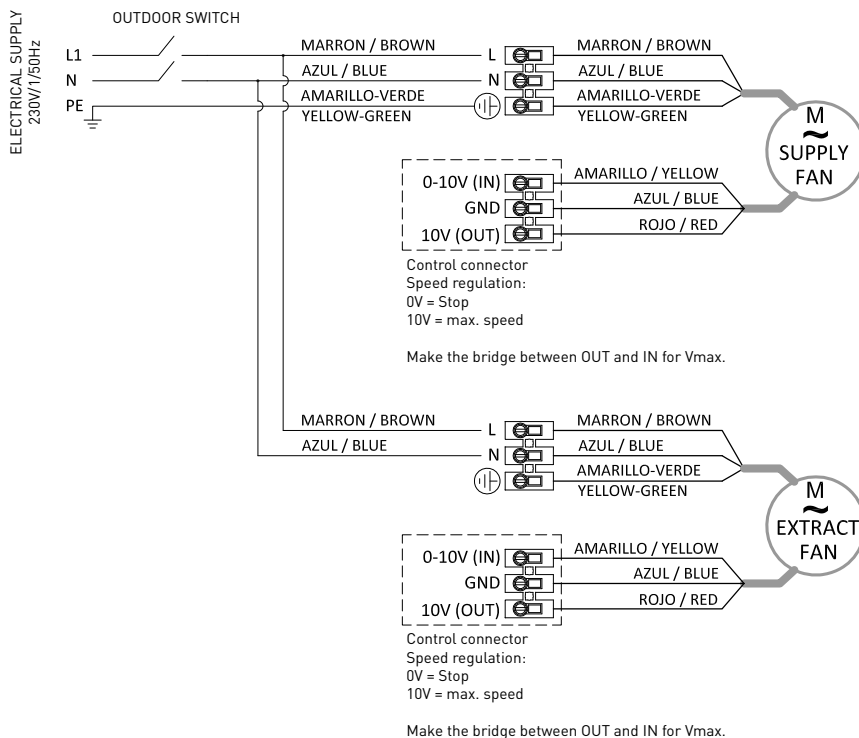



### Horizontal version CADB/T-HE 33 LH/RH

In this size the units have plug-fans equipped with EC motors with power supply to three-phase 400V.

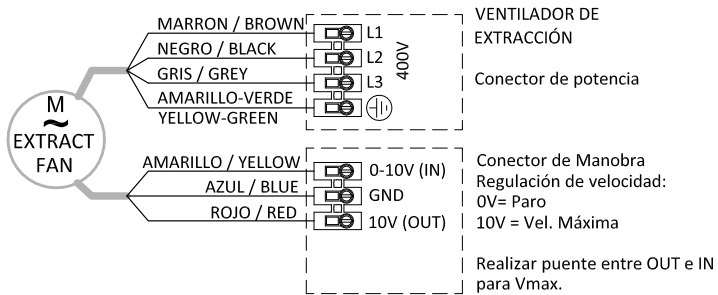
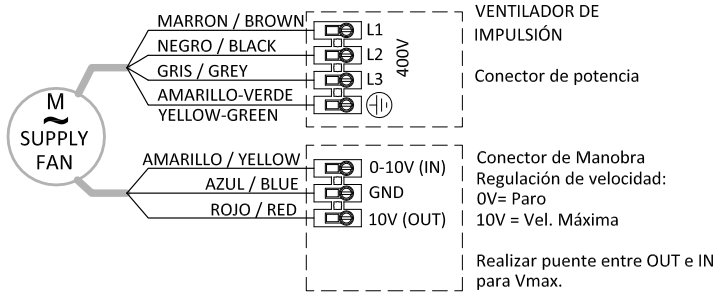

### Vertical versions CADB/T-HE 33 LV/RV

In this size the units have plug-fans equipped with EC motors with power supply to three-phase 400V.

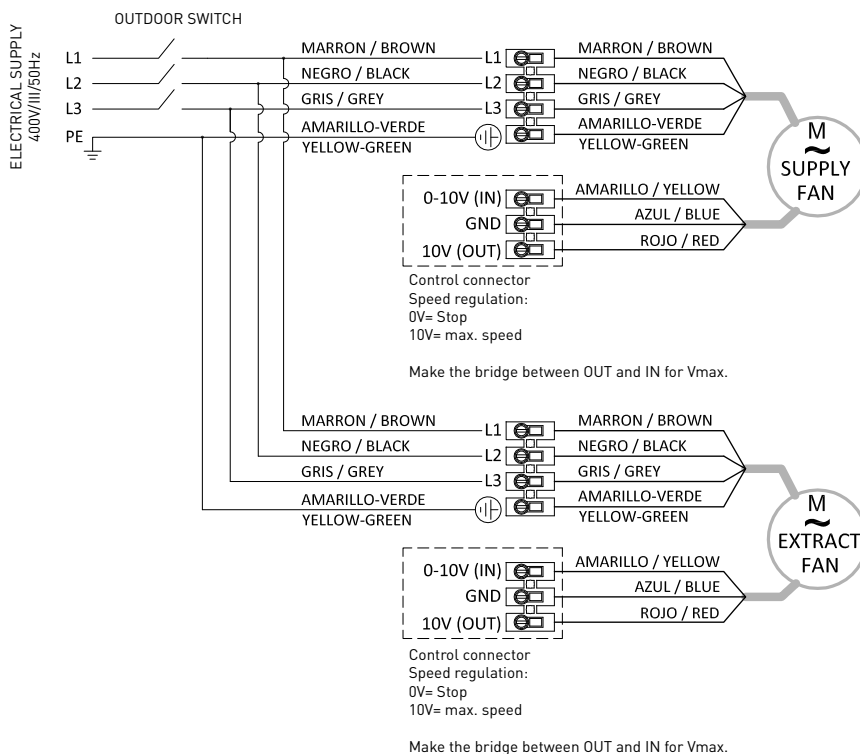



### CADB/T-HE 45, 60 and 100 models

The models of sizes 45 to 100 have three phase motors EC. Three-phase power EC. All versions include a cut-out switch to which the fan power is wired.

In the case of -DI versions equipped with resistances of post electric heating. The current cut-out control of the resistances must be carried out by the electric installer.

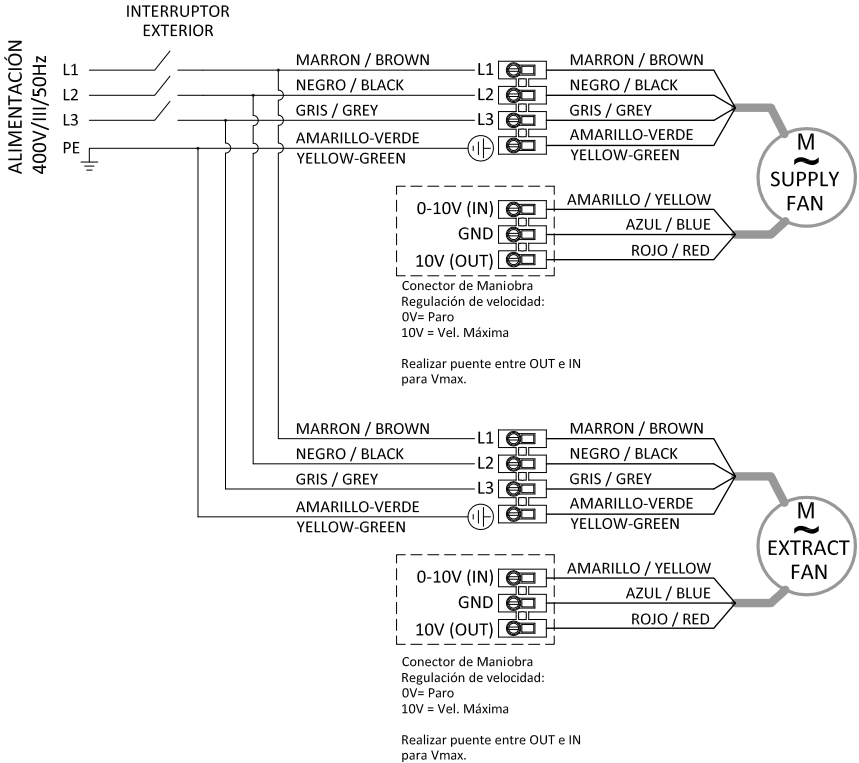

### 6.6.2. Connecting the By-pass

All heat recovery units of the CADB/T-HE ECOWATT range have an internal by-pass. The by-pass damper is supplied with its actuator mounted (Supply voltage 230V). The actuator is wired to an external terminal box or to the electrical board (depending on the version).

With the FC-REG accessory it is possible to control the by-pass in free-cooling mode.

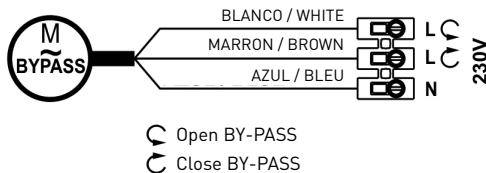

### 6.6.3. Connecting the electric batteries

The CADB/T-HE-DI versions are supplied with electrical batteries of postheating mounted inside the unit.



**FIRE DANGER**

To manage the internal electrical power (-DI versions) it is necessary to perform an external electrical operation control board.

The installer is responsible for the correct operation of the electrical control, specially regarding those safety requirements to avoid fire risk due to high temperature inside the unit.

#### Electrical diagrams (Recommended control board)

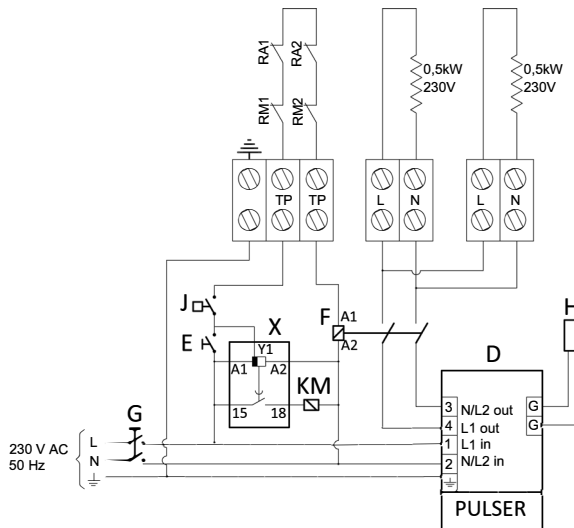

**CADB-HE-DI 04 (1kW 230V)**

D: HEATER REGULATOR  
 E: ON/OFF SWITCH  
 F: RELAY  
 G: LINE PROTECTION

H: TEMPERATURE PROBE (TG-K330)  
 J: FLOW DETECTOR  
 KM: FAN RELAY  
 X: TIMER (MCR-1)

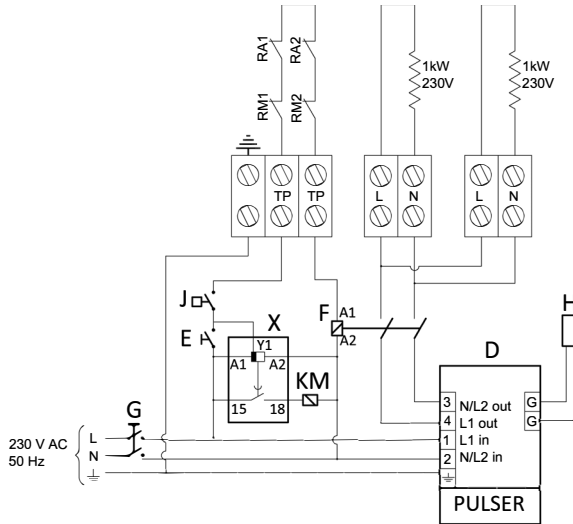

CADB-HE-DI 08 (2kW 230V)

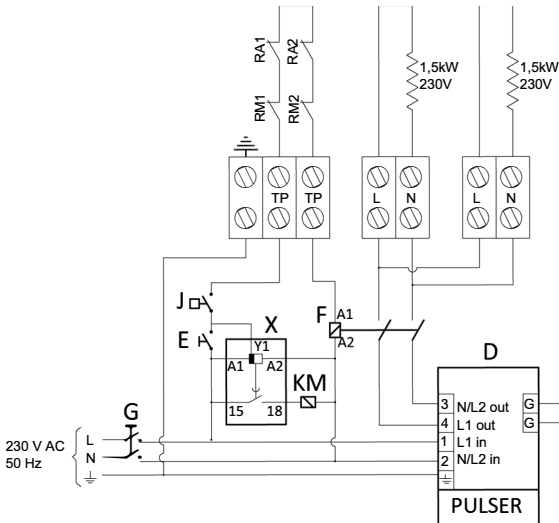

CADB-HE-DI 12 (3kW 230V)

D: HEATER REGULATOR  
 E: ON/OFF SWITCH  
 F: RELAY  
 G: LINE PROTECTION

H: TEMPERATURE PROBE (TG-K330)  
 J: FLOW DETECTOR  
 KM: FAN RELAY  
 X: TIMER (MCR-1)

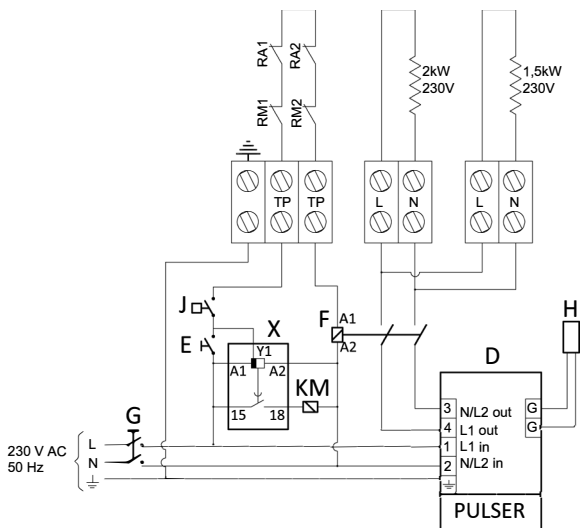

CADB-HE-DI 16 (3,5kW 230V)

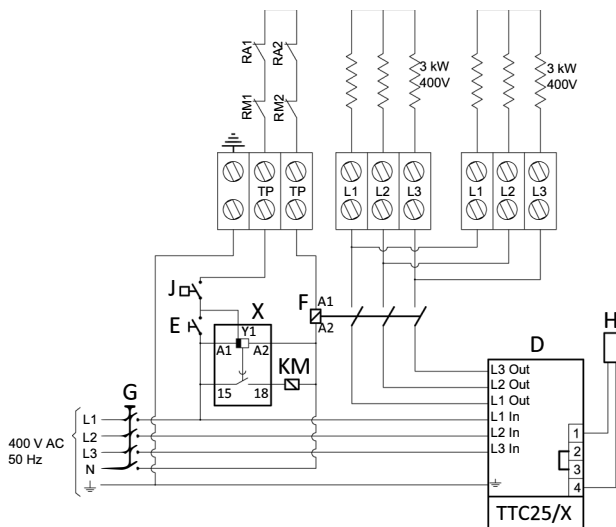

CADB-HE-DI 21/27 (6kW 400V)

D: HEATER REGULATOR  
 E: ON/OFF SWITCH  
 F: RELAY  
 G: LINE PROTECTION

H: TEMPERATURE PROBE (TG-K330)  
 J: FLOW DETECTOR  
 KM: FAN RELAY  
 X: TIMER (MCR-1)

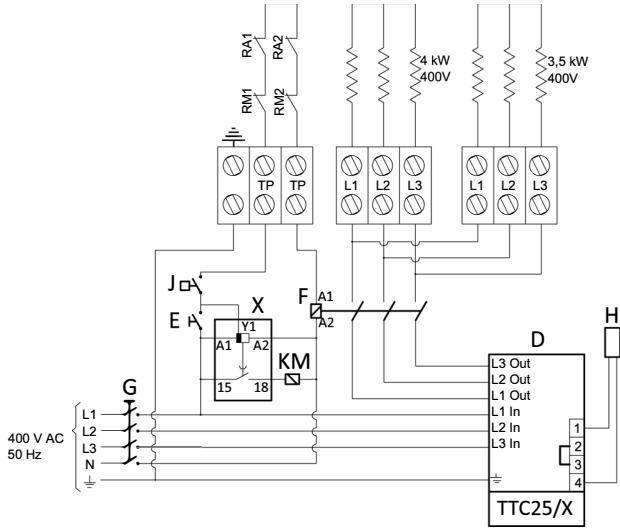

CADB-HE-DI 33 (7,5kW 400V)

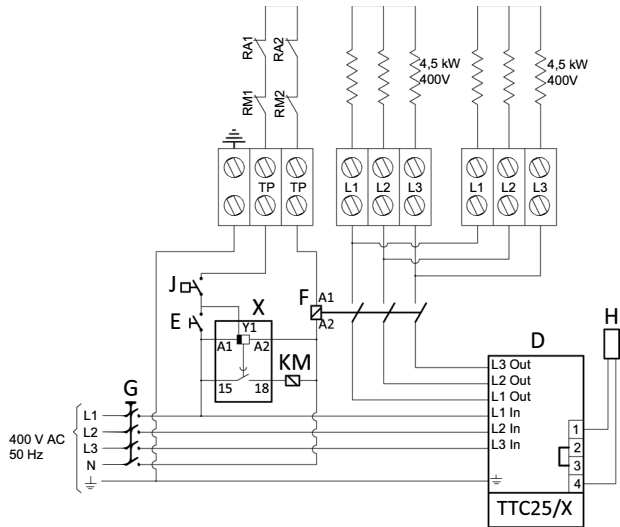

CADB-HE-DI 45 (9kW 400V)

D: HEATER REGULATOR  
E: ON/OFF SWITCH  
F: RELAY  
G: LINE PROTECTION

H: TEMPERATURE PROBE (TG-K330)  
J: FLOW DETECTOR  
KM: FAN RELAY  
X: TIMER (MCR-1)



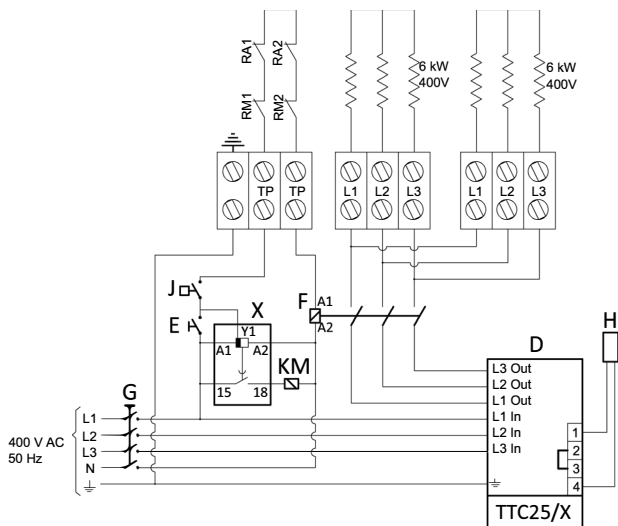

CADB-HE-DI 60 (12kW 400V)

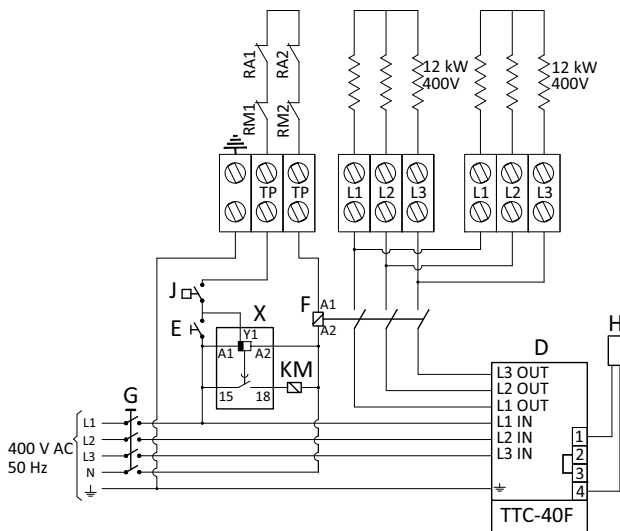

CADT-HE 100 (24kW 400V))

D: HEATER REGULATOR  
 E: ON/OFF SWITCH  
 F: RELAY  
 G: LINE PROTECTION

H: TEMPERATURE PROBE (TG-K330)  
 J: FLOW DETECTOR  
 KM: FAN RELAY  
 X: TIMER (MCR-1)



## Thermal protectors

The electric heaters are equipped with two thermal protectors (automatic and manual reset). Both protectors are safety devices to be used exclusively to detect abnormal functioning of the heating system. Under no circumstances the thermal protectors can be used as thermostats to control the heating power. Before reset the manual thermal protector, ensure that the causes that produced its activation were located and corrected.

### Thermal protectors position

Horizontal models:

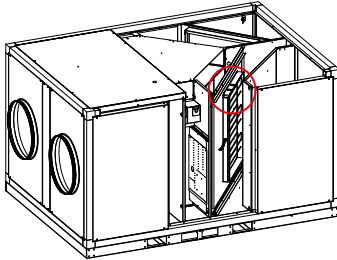

Vertical models:

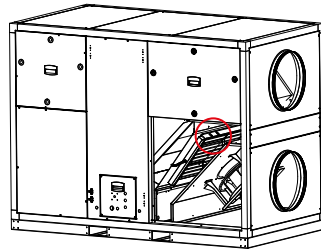

Danger of burns, there is a risk that the metal parts are at a high temperature.

#### 6.6.4. Connecting electrical accessories

With the existing accessories is possible to perform the fans control in VAV, COP and CAV mode.

#### Recommended accessories depending on the unit size and the control mode:

Model	Accessories for VAV via CO <sub>2</sub>		Accessories for COP		Accessories for CAV
	Converter	Sensor	Converter	Sensor	Electronic regulator
CADB-HE D/DI/DC 04	CONTROL AERO-REG	SC02-A 0-10V SC02-AD 0-10V SC02-G 0-10/V	CONTROL AERO-REG**	TDP-D*	REB-ECOWATT**
CADB-HE D/DI/DC 08					
CADB-HE D/DI/DC 12					
CADB-HE D/DI/DC 16					
CADB-T-HE D/DI/DC 21					
CADT-HE D/DI/DC 33***					
CADT-HE D/DI/DC 45***					
CADT-HE D/DI/DC 60***					
CADT-HE D/DI/DC 100***					

\* To independently control the workpoint of each circuit, the supply and extract fans should be controlled by two specific pressure probes.

\*\* To independently control the workpoint of each circuit, the supply and extract fans should be controlled via corresponding electronic regulator.

\*\*\* In the models with three-phase motor it will be necessary to add two auxiliary contactors (not supplied by S&P) that allow to cut the power supply of the motors.

### 6.6.4.1. Manual VAV control (variable airflow)

It is possible to control in VAV mode manually with an external potentiometer. Manual control by external potentiometer REB-ECOWATT (accessory). Valid for CADB/T-HE 04 to 27 models.



**IMPORTANT: RISK OF FIRE**

The manual speed control, must not be carried out in DI-versions (with electrical resistances).

The direct stop of the fans without a temporized stop would cause a high temperature rise of the resistances, and the consequent risk of fire inside the unit.

#### 6.6.4.1.1. 04 to 27 models: Manual adjustment by REB-ECOWATT (accessory)

##### Simultaneous control of the supply and extract fans

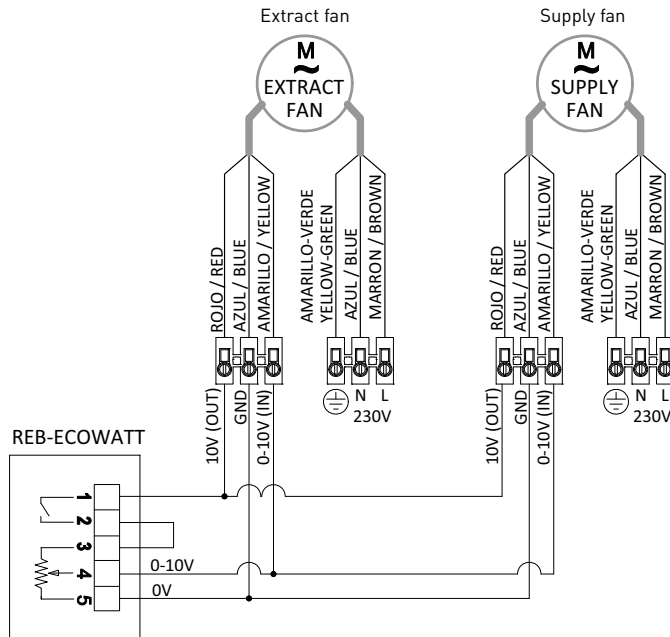

### Independent control of supply and extract fans

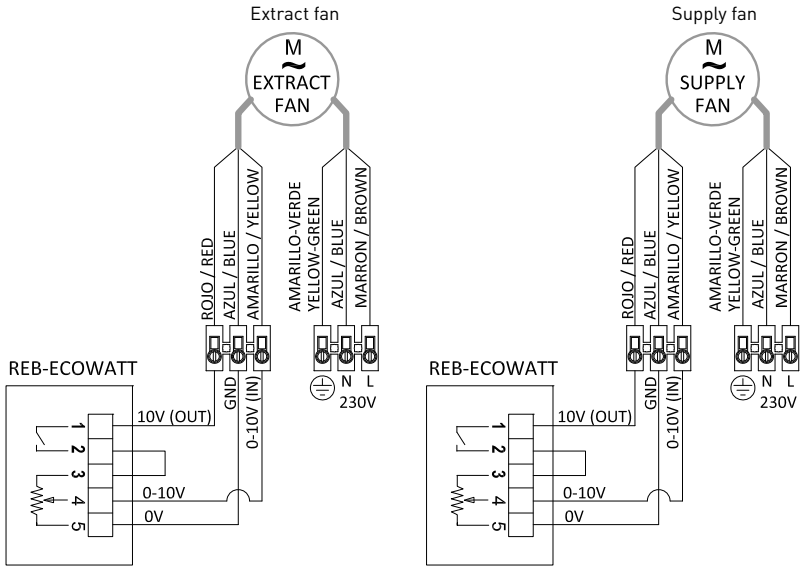

### 6.6.4.1.2. 33, 45, 60 and 100 models: Manual adjustment by REB-ECOWATT (accessory)

#### Simultaneous control of the supply and extract fans

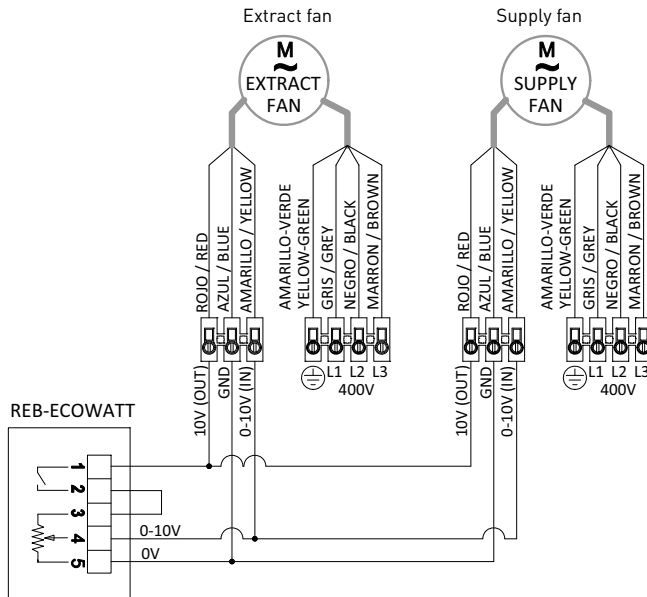

## Independent control of supply and extract fans

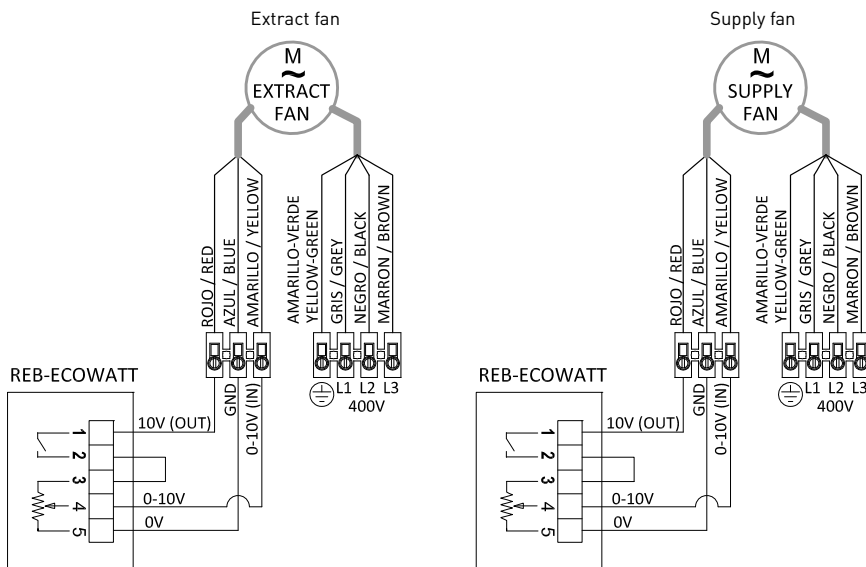

### 6.6.4.2. VAV Control (variable airflow), with CO<sub>2</sub> sensor or similar



#### FIRE DANGER

For DI heat recovery units, equipped with electric post heating battery, the installer must ensure that the minimum airflow is enough to prevent electrical battery overheating. We recommend that minimum airflow was not less than 1/3 part of the heat recovery unit nominal airflow.

All CADB-HE are equipped with EC motors, single-phase 230V power on models 04 to 27 and three-phase 400V on models 33 to 100. The motors have specific terminals for sending a regulation signal to control fan speed (0-10V). The 0V signal corresponds to the fan stop, while the signal of 10V corresponds to fan maximum speed.

To perform the speed regulation in VAV with speed control with external sensor of CO<sub>2</sub> or similar, it is necessary to use the accessory CONTROL AERO-REG and the external sensor (see point 7.5.2.4.). In the CONTROL AERO-REG instruction booklet it is contained the necessary information to carry on the electrical connection of the different components.

### 6.6.4.3. CAV control (Constant airflow)

The inverter is used to guarantee an specific constant air volume in the duct system, regardless of the filters clogging state.

All CADB-HE are equipped with EC motors, single-phase 230V power on models 04 to 27 and three-phase 400V on models 33 to 100. The motors have specific terminals for sending a regulation signal to control fan speed (0-10V).



The 0V signal corresponds to the fan stop, while the signal of 10V corresponds to fan maximum speed.

To perform the speed regulation in CAV mode, it is necessary to use the accessory CONTROL AERO-REG and the external pressure sensor TDP-D. In the CONTROL AERO-REG instruction booklet it is contained the necessary information to carry on the electrical connection of the different components.

1° Connect the pressure transmitter TDP-D (accessory) to the specific pressure taps there are in the heat recovery unit. Ensure that pressure taps “ + ” and “ - ”. Same sign in the taps of TDP-D and CADB-HE.

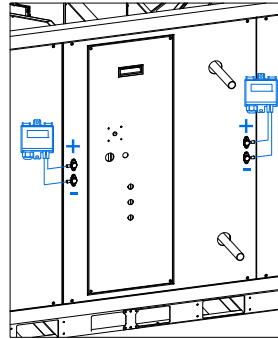
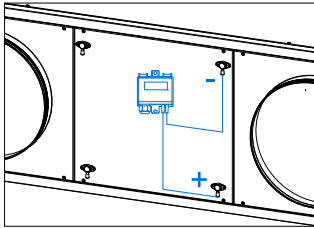

3°. Reconfigure the pressure transmitter. Select the TPD-D sensor pressure range in accordance with the values in the third column in the table above.

#### Adjustment to work in airflow mode:

The selection between pressure and airflow is made by the DIP3(SW1) micro switch existing inside the micro switch. Fix the micro switch in ON position.

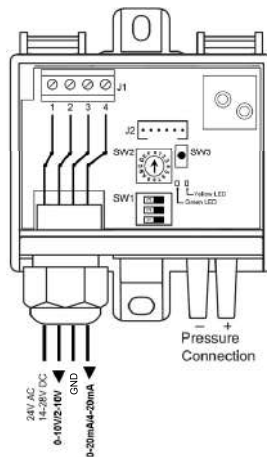

### Indicate the airflow range:

Once configured the airflow measurement, press the "OK" button to set the first digit of factor k. The value flashes and is adjusted using the buttons "▲" and "▼". When set, press the "OK" button to memorise the factor k. The actual measured value is displayed. If a airflow range is selected it is not necessary to enter a range of pressures.

Model	K Factor
CADB-HE 04	46
CADB-HE 08	69
CADB-HE 12	69
CADB-HE 16	69
CADB/T-HE 21	131
CADB/T-HE 27	95
CADT-HE 33	131
CADT-HE 45	188
CADT-HE 60	192
CADT-HE 100	365

#### 6.6.4.4. COP Control (Constant pressure)

##### Constant Pressure (COP)

The inverter is used in multiroom ventilation systems to guarantee a constant air pressure value in the duct system, regardless of whether the dampers are open or closed.

In both cases, the pressure must be constant in the duct system. The value of this pressure must be determined by experimenting during the system start-up process.

All CADB-HE are equipped with EC motors, single-phase 230V power on models 04 to 27 and three-phase 400V on models 33 to 100. The motors have specific terminals for sending a regulation signal to control fan speed (0-10V).

The 0V signal corresponds to the fan stop, while the signal of 10V corresponds to fan maximum speed.

To perform the speed regulation in COP mode, it is necessary to use the accessory CONTROL AERO-REG and the external pressure sensor TDP-D. In the CONTROL AERO-REG instruction booklet it is contained the necessary information to carry on the electrical connection of the different components.

- 1° Connect the pressure transmitter TDP-D (accessory) to the duct system where the heat recovery unit is ducted. Ensure that pressure taps "+" and "-" are in the right position according to the following images.

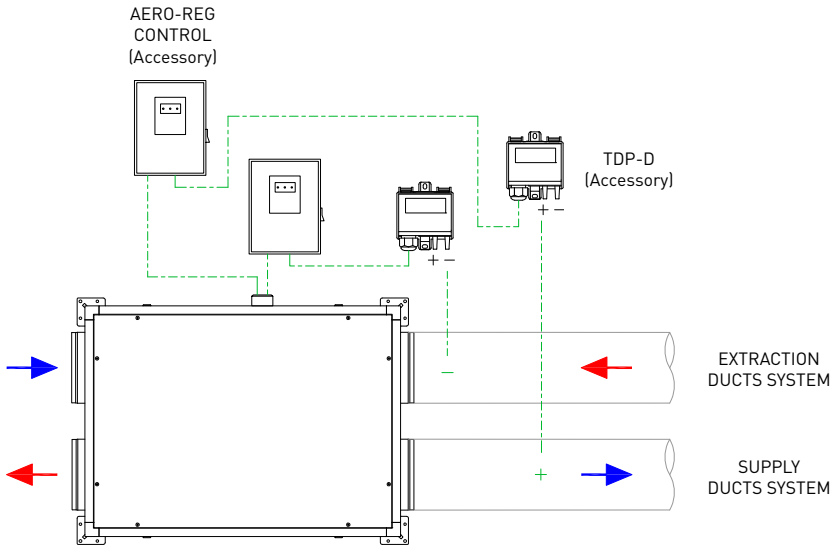
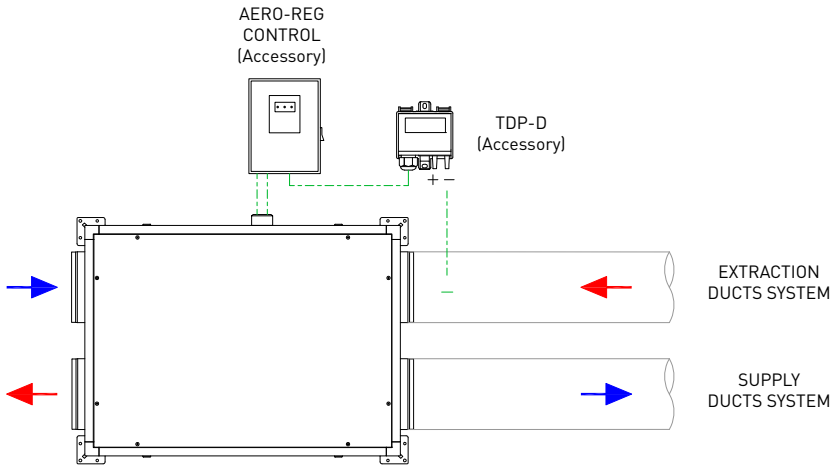

**6.6.4.5. Pressure switch connection**

All these range of heat recovery units have pressure tapping that allow the installation of differential pressure switches to perform the control of polluted filters. The position of the pressure taps depends on the model:



### HORIZONTAL MODELS

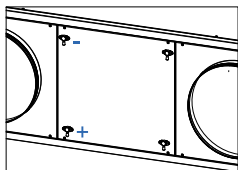

Horizontal models  
CADB/T-HE 04 to 33 LH, RH  
(on the side of inlet connection panel)

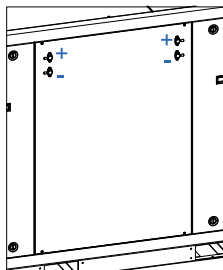

Horizontal models  
CADB/T-HE 45 to 60 LH, RH  
(on superior part of the side panel)

### VERTICAL MODELS

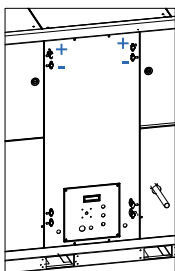

Vertical models  
CADB/T-HE 45 to 100 LV, RV  
(on superior part of the side panel)

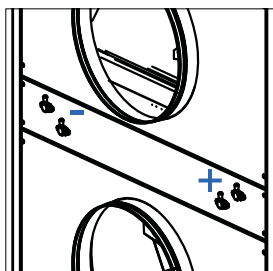

Vertical models  
CADB/T-HE 04 to 33 LV, RV  
(in the central part of the front panel)

## 6.7. REVERSE SUPPLY AIR/ EXTRACT AIR SIDE (only -D version)

In models CADB-HE-D 04 to CADB-HE-D 33 it is possible to reverse the supply and extract air sides.

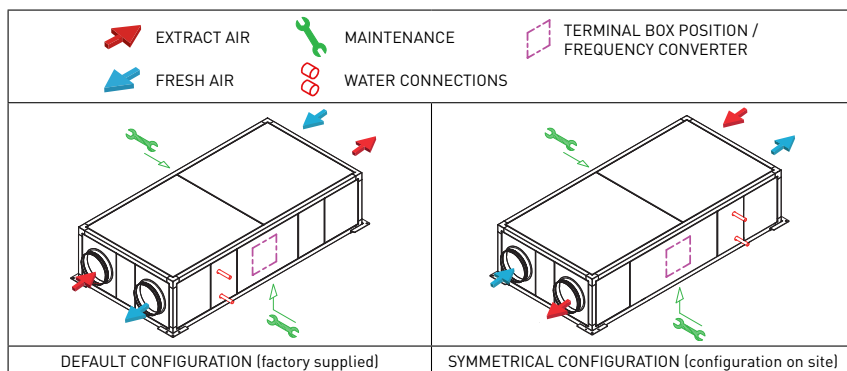



To carry on this modification it is necessary to make the following modifications to the unit:

1. Exchange the supply and extract filters as well as the access covers to the filters.
2. Replace the labels that identify the function of the air inlet/outlet. To do this, a new set of labels is supplied with the unit.
3. Replace the electrical connection label existing in the back side of the electrical terminal box with the one symmetrical label supplied in the accessory bag.
4. Only in cold climates where by-pass is used as part of the defrost strategy of the heat exchanger: Reverse the direction of the by-pass so that it remains at the supply of the unit.

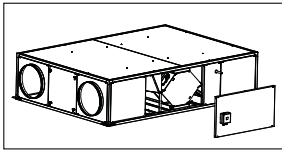

Fig. 1

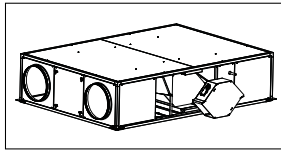

Fig. 2

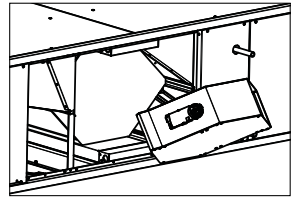

Fig. 3

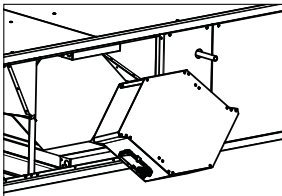

Fig. 4

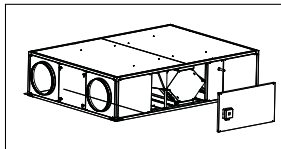

Fig. 5

1. Disconnect the heat recovery unit.
2. Remove the side panel (fig.1).
3. Extract carefully the bypass (fig.2).
4. Disconnect the electrical connector that feeds the bypass.
5. Turn the bypass according to image (fig.3 and 4).
6. Reconnect the electrical power connector of bypass.
7. Place the bypass in its housing again (fig.5), close the panel and start up the unit.

## 6.8. CONFIGURATIONS

### CADB/T-HE D/DI/DC ECOWATT standard configuration

From these configurations there are multiple variables that can be performed by the professional installer quickly and easily.

#### Panel replacement process



The CADB-HE heat recovery units are available in two configurations LH, RH in horizontal models and LV, RV in vertical models.

EXTRACT AIR    
 FRESH AIR    
 WATER CONNECTIONS    
 TERMINAL BOX POSITION / FREQUENCY CONVERTER

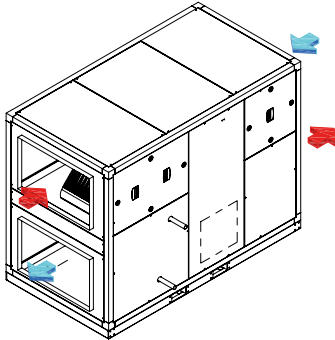

Conf. LV

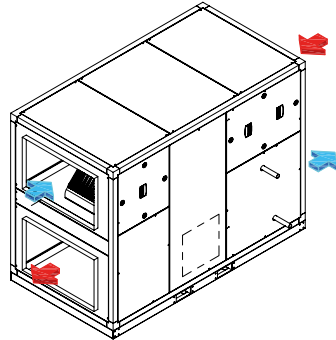

Conf. RV

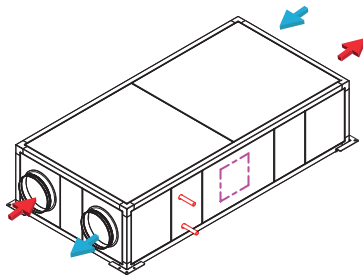

Conf. LH

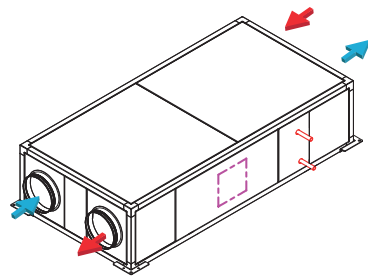

Conf. RH

### Horizontal

Factory configuration

LH

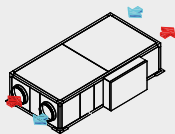

Examples of some of the configurations that is possible to obtain from factory configuration

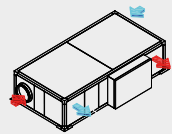
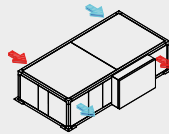
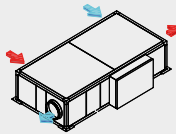

RH

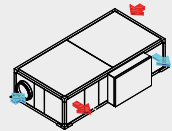
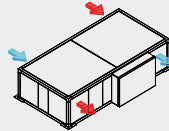
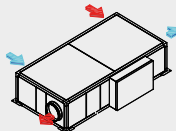
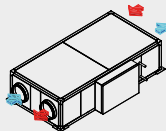

## Vertical

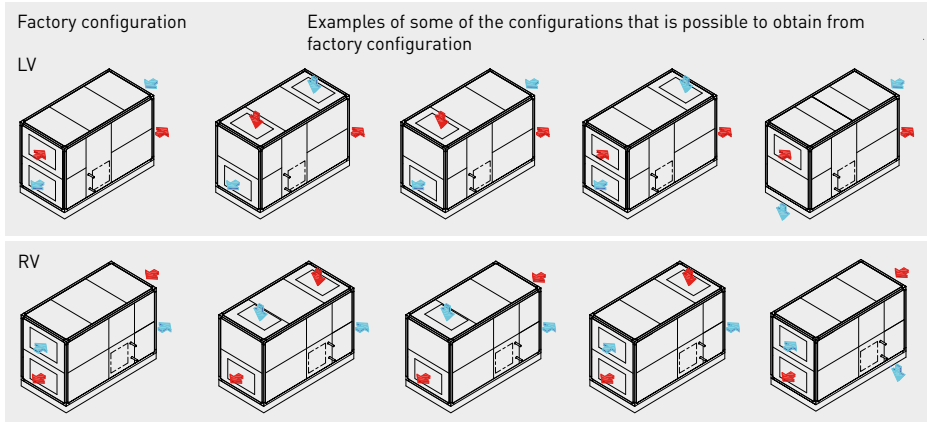

## 6.9. CONTROL OF COOLING EXTERNAL BATTERIES

The heat recovery units CADB-HE are complemented by a complete range of air treatment accessories consisting of:

- Cold water battery module.
- Double battery module (cold water and hot water).
- Direct expansion battery modules.
- Exterior filtration module.
- Air purification module, specific for areas with high external pollution.

Its quick mounting system and its perfect integration with the heat recovery unit provides a considerable saving in the mounting time comparing them with the conventional accessories.

List of accessories by models:

Heat recovery unit model		Cold water battery	Direct expansion battery	Cold water battery + hot water battery (4 tubes)	Filtration module	Purification module Exterior pollution
HORIZONTAL CONFIGURATION						
CADB-HE-D/DI/DC 04	LH	BA-AF HE 04 LH	BA-DX HE 04 LH	BA-AFC HE 04 LH	FBL HE 04 H	FB-CA HE 04 H
	RH	BA-AF HE 04 RH	BA-DX HE 04 RH	BA-AFC HE 04 RH		
CADB-HE-D/DI/DC 08	LH	BA-AF HE 08 LH	BA-DX HE 08 LH	BA-AFC HE 08 LH	FBL HE 08 H	FB-CA HE 08 H
	RH	BA-AF HE 08 RH	BA-DX HE 08 RH	BA-AFC HE 08 RH		
CADB-HE-D/DI/DC 12	LH	BA-AF HE 12 LH	BA-DX HE 12 LH	BA-AFC HE 12 LH	FBL HE 12 H	FB-CA HE 12 H
	RH	BA-AF HE 12 RH	BA-DX HE 12 RH	BA-AFC HE 12 RH		
CADB-HE-D/DI/DC 16	LH	BA-AF HE 16 LH	BA-DX HE 16 LH	BA-AFC HE 16 LH	FBL HE 16 H	FB-CA HE 16 H
	RH	BA-AF HE 16 RH	BA-DX HE 16 RH	BA-AFC HE 16 RH		
CADB/T-HE-D/DI/DC 21	LH	BA-AF HE 21-27 LH	BA-DX HE 21-27 LH	BA-AFC HE 21-27 LH	FBL HE 21-27 H	FB-CA HE 21-27 H
	RH	BA-AF HE 21-27 RH	BA-DX HE 21-27 RH	BA-AFC HE 21-27 RH		
CADT-HE-D/DI/DC 33	LH	BA-AF HE 33 LH	BA-DX HE 33 LH	BA-AFC HE 33 LH	FBL HE 33 H	FB-CA HE 33 H
	RH	BA-AF HE 33 RH	BA-DX HE 33 RH	BA-AFC HE 33 RH		
CADT-HE-D/DI/DC 45	LH	BA-AF HE 45 LH	BA-DX HE 45 LH	BA-DX HE 45 LH	FBL HE 45 H	FB-CA HE 45 H
	RH	BA-AF HE 45 RH	BA-DX HE 45 RH	BA-DX HE 45 RH		
CADT-HE-D/DI/DC 60	LH	BA-AF HE 60 LH	BA-DX HE 60 LH	BA-DX HE 60 LH	FBL HE 60 H	FB-CA HE 60 H
	RH	BA-AF HE 60 RH	BA-DX HE 60 RH	BA-DX HE 60 RH		

Heat recovery unit model		Cold water battery	Direct expansion battery	Cold water battery + hot water battery (4 tubes)	Filtration module	Purification module Exterior pollution
VERTICAL CONFIGURATION						
CADB-HE-D/DI/DC 04	LV	BA-AF HE 04 LV	BA-DX HE 04 LV	BA-AFC HE 04 LV	FBL HE 04 V	FB-CA HE 04 V
	RV	BA-AF HE 04 RV	BA-DX HE 04 RV	BA-AFC HE 04 RV		
CADB-HE-D/DI/DC 08	LV	BA-AF HE 08 LV	BA-DX HE 08 LV	BA-AFC HE 08 LV	FBL HE 08 V	FB-CA HE 08 V
	RV	BA-AF HE 08 RV	BA-DX HE 08 RV	BA-AFC HE 08 RV		
CADB-HE-D/DI/DC 12	LV	BA-AF HE 12 LV	BA-DX HE 12 LV	BA-AFC HE 12 LV	FBL HE 12 V	FB-CA HE 12 V
	RV	BA-AF HE 12 RV	BA-DX HE 12 RV	BA-AFC HE 12 RV		
CADB-HE-D/DI/DC 16	LV	BA-AF HE 16 LV	BA-DX HE 16 LV	BA-AFC HE 16 LV	FBL HE 16 V	FB-CA HE 16 V
	RV	BA-AF HE 16 RV	BA-DX HE 16 RV	BA-AFC HE 16 RV		
CADB/T-HE-D/DI/DC 21	LV	BA-AF HE 21-27 LV	BA-DX HE 21-27 LV	BA-AFC HE 21-27 LV	FBL HE 21-27 V	FB-CA HE 21-27 V
CADB/T-HE-D/DI/DC 27	RV	BA-AF HE 21-27 RV	BA-DX HE 21-27 RV	BA-AFC HE 21-27 RV		
CADT-HE-D/DI/DC 33	LV	BA-AF HE 33 LV	BA-DX HE 33 LV	BA-AFC HE 33 LV	FBL HE 33 V	FB-CA HE 33 V
	RV	BA-AF HE 33 RV	BA-DX HE 33 RV	BA-AFC HE 33 RV		
CADT-HE-D/DI/DC 45	LV	BA-AF HE 45 LV	BA-DX HE 45 LV	BA-DX HE 45 LV	FBL HE 45 V	FB-CA HE 45 V
	RV	BA-AF HE 45 RV	BA-DX HE 45 RV	BA-DX HE 45 RV		
CADT-HE-D/DI/DC 60	LV	BA-AF HE 60 LV	BA-DX HE 60 LV	BA-DX HE 60 LV	FBL HE 60 V	FB-CA HE 60 V
	RV	BA-AF HE 60 RV	BA-DX HE 60 RV	BA-DX HE 60 RV		
CADB/T-HE-D/DI/DC 100	LV	BA-AF HE 100 LV	BA-DX HE 100 LV	BA-DX HE 100 LV	FBL HE 100 V	FB-CA HE 100 V
	RV	BA-AF HE 100 RV	BA-DX HE 100 RV	BA-DX HE 100 RV		

### 6.9.1. Accessories assembly

Accessories are installed on the supply air outlet. IAQ module, FB-CA HE can also be mounted on the exhaust air outlet, for those applications in which, it will be necessary to eliminate or reduce the odor concentration in the exhaust air.

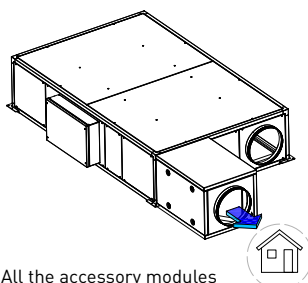

All the accessory modules can be mounted on the supply air outlet

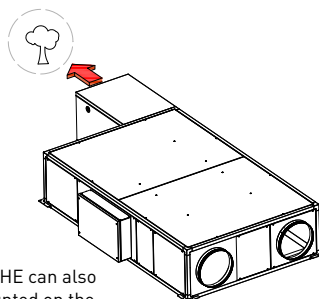

FB-CA HE can also be mounted on the exhaust air outlet

To proceed with the assembly, follow the next steps:

1. Remove the flange panel from the heat recovery unit, loosen the 4 screws that fix it.

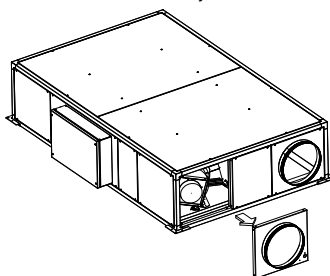



2. Mount the centering frame, by means of the 4 screws M5X12. Both centering frame and screws are delivered with the module.

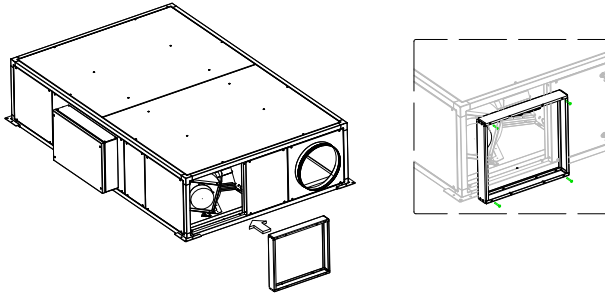

Before mounting the centering frame, verify that the locating lip in the frame is positioned in the top side.

Centering frame locating lip

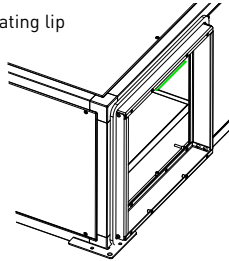

3. Put the self-adhesive sealing strip, delivered in a bag included with the module, around the centering frame.

The self-adhesive side must be in direct contact with the CADB-HE profiles. Do not adhesive the sealing strip to the centering frame

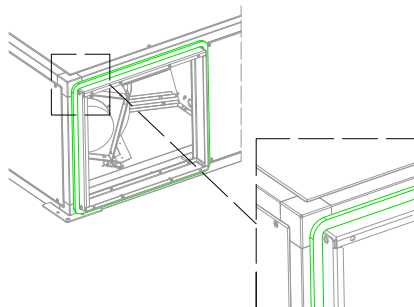

4. Hook the module onto the centering frame locating lip, and then drop it by its own weight.

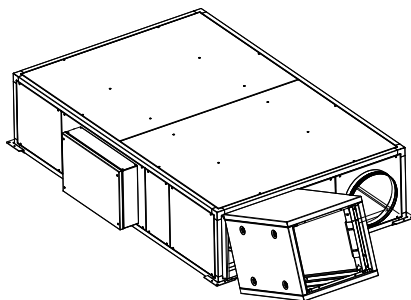

Fix the module to the heat recovery unit permanently. The access to fixing points is performed by the side of the unit, removing one of the side panels (from the CADB or from the module maintenance panel).

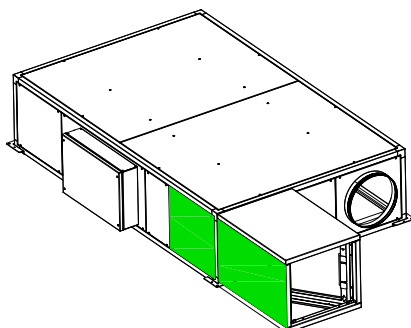

To carry it out, use the 4 screwed knobs delivered with the module.

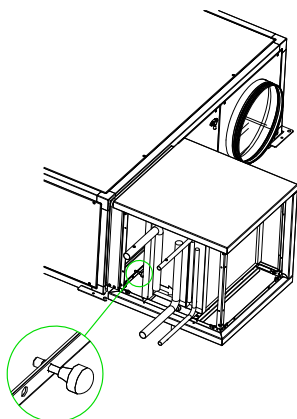



5. Finally place the flange panel (that was disassembled at the first step) over the module outlet using the 4 screws that fixed the panel to the CADB-HE.

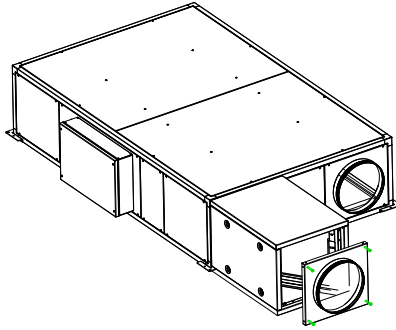

6. Particularities of the modules with coils

In the installation of external modules (accessories) with water coil or refrigerant coil, the assembly of the module should be done in the way that:

- Air and water/refrigerant flows circulate in counterflow
- Water/Refrigerant inlet connection should be in the coil lower part

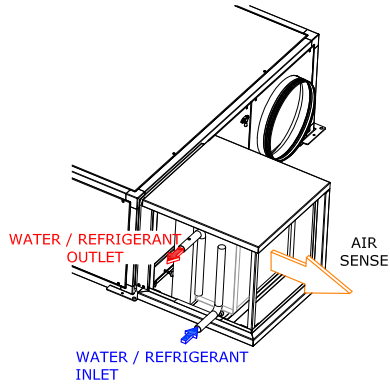



## 6.9.2. Coils characteristics

### 6.9.2.1. Cold water coils for 2 pipes installation

Model	Air			Fresh Air		Exhaust Air		kW	Water	
	(m <sup>3</sup> /h)	(Pa)	(m/s)	(°C)	(%)	(°C)	(%)		(l/h)	(kPa)
COLD WATER COIL (4 Rows) Water Inlet/Outlet = 7/12°C										
BA-AF HE 04	320	87	1,8	27	80	14,8	100	3,26	561	25
BA-AF HE 08	600	75	1,7			14,7		6,14	1055	38
BA-AF HE 12	900	171	2,4			14,5		9,4	1605	19
BA-AF HE 16	1.200	175	2,5			14,2		12,8	2200	42
BA-AF HE 21	1.600	105	2			14,6		16,5	2830	42
BA-AF HE 33 LH/RH	2.400	200	2,7			14,6		24,7	4245	26
BA-AF HE 33 LV/RV	2.400	148	2,2			14,3		25,3	4345	19
BA-AF HE 45	3.400	158	2,5			16		31,3	5372	13
BA-AF HE 60	4.400	151	2,4			15,7		41,5	7120	16
COLD WATER COIL in Heat Mode (4 Rows) Water Inlet/Outlet = 50/45°C										
BA-AF HE 04	320	51	1,8	16	18	42,7	4	2,9	501	4,7
BA-AF HE 08	600	44	1,7			41,6		5,2	903	11,7
BA-AF HE 12	900	95	2,4			43		8,3	1427	17
BA-AF HE 16	1.200	105	2,5			42,8		11	1890	26,2
BA-AF HE 21	1.600	60	2			42		14,2	2447	25,7
BA-AF HE 33 LH/RH	2.400	111	2,7			42,6		21,8	3754	22,8
BA-AF HE 33 LV/RV	2.400	83	2,2			42,9		22	3798	16,1
BA-AF HE 45	3.400	88	2,5			41		29,3	5045	13,2
BA-AF HE 60	4.400	56	1,9			42,7		31	5345	10,3

### 6.9.2.2. Cold water coils for for 4 pipes installation

Model	Air			Fresh Air		Exhaust Air		kW	Water	
	(m <sup>3</sup> /h)	(Pa)	(m/s)	(°C)	(%)	(°C)	(%)		(l/h)	(kPa)
COLD WATER COIL (4 Rows) Water inlet/outlet = 7/12°C										
BA-AFC HE 04	320	87	1,8	27	80	14,8	100	3,26	561	25
BA-AFC HE 08	600	75	1,7			14,7		6,14	1055	38
BA-AFC HE 12	900	171	2,4			14,5		9,4	1605	19
BA-AFC HE 16	1.200	175	2,5			14,2		12,8	2200	42
BA-AFC HE 21	1.600	105	2			14,6		16,5	2830	42
BA-AFC HE 33 LH/RH	2.400	200	2,7			14,6		24,7	4245	26
BA-AFC HE 33 LV/RV	2.400	148	2,2			14,3		25,3	4345	19
BA-AFC HE 45	3.400	158	2,5			16		31,3	5372	13
BA-AFC HE 60	4.400	151	2,4			15,7		41,5	7120	16
HOT WATER COIL Water inlet/outlet = 80/60°C										
BA-AFC HE 04	320	20	2	16	18	40,5	4	2,7	115	1
BA-AFC HE 08	600	23	1,7			43,7		5,7	243	1
BA-AFC HE 12	900	37	2,4			40,9		7,7	329	2
BA-AFC HE 16	1.200	39	2,4			41,7		10,5	451	3
BA-AFC HE 21	1.600	24	2			40,7		13,5	580	2,3
BA-AFC HE 33 LH/RH	2.400	41	2,7			38,2	18,1	780	1	
BA-AFC HE 33 LV/RV	2.400	30	2,2			38,7	18,5	798	0,6	
BA-AFC HE 45	3.400	38	2,5			38,8	26,5	1139	1	
BA-AFC HE 60	4.400	36	2,5			39,4	35,2	1511	2	



### 6.9.2.3. Expansion coils for integration in DX systems

Model	Air			Fresh Air		Exhaust Air		Cooling Power 7°C EVAP (kW)	R-410A Refrigerant		
	Airflow (m³/h)	Pressure drop (Pa)	Speed (m/s)	(°C)	(%)	(°C)	(%)		(l/h)	(kPa)	(dm³)

#### DX BATTERY - COOLING

BA-DX HE 04	320	95	1,8	27	80	15,2	100	3,15	61	6,8	0,7	
BA-DX HE 08	600	80	1,7					14,5	6,26	122	32	1,2
BA-DX HE 12	900	189	2,4					14,5	9,43	175	20	1,7
BA-DX HE 16	1.200	199	2,5					14,4	12,6	245	26	1,8
BA-DX HE 21	1.600	107	2					14,7	16,5	321	29	2,6
BA-DX HE 33 LH/RH	2.400	233	2,7					14,6	24,9	464	15	3,9
BA-DX HE 33 LV/RV	2.400	163	2,2					14	26	484	19	3,8
BA-DX HE 45 LH/RH	3.400	198	2,5					14,8	34,5	731	12,5	5,7
BA-DX HE 45 LV/RV	3.400	198	2,5					14,4	35,7	756	20	5,6
BA-DX HE 60 LH/RH	4.400	189	2,5					14,6	45,5	950	14	7,4
BA-DX HE 60 LV/RV	4.400	196	2,5	14,4	46,5	984	18	6,7				

#### DX BATTERY - HEATING

Model	Air			Fresh Air		Exhaust Air		Heating Power T <sub>COND.</sub> = 39°C (kW)	R-410A Refrigerant				
	Airflow (m³/h)	Pressure drop (Pa)	Speed (m/s)	(°C)	(%)	(°C)	(%)		(l/h)	(kPa)	(dm³)		
BA-DX HE 04	320	56	1,8	16	18	33,4	8	1,8	33	1,2	0,7		
BA-DX HE 08	600	47	1,7					33	6	3,5	64	6,1	1,2
BA-DX HE 12	900	105	2,4					33,2	6	5,3	92	4,7	1,7
BA-DX HE 16	1.200	117	2,5					33,7	6	7,2	134	4,8	1,8
BA-DX HE 21	1.600	76	2					34,5	6	10,1	186	6,8	2,6
BA-DX HE 33 LH/RH	2.400	130	2,7					33,2	6	14,1	245	3,6	3,9
BA-DX HE 33 LV/RV	2.400	91	2,2					33,7	6	14,5	253	4,5	3,8
BA-DX HE 45 LH/RH	3.400	110	2,5					32,7	7	19,4	357	2,6	5,7
BA-DX HE 45 LV/RV	3.400	110	2,5					33,2	6	19,9	367	4,2	5,6
BA-DX HE 60 LH/RH	4.400	105	2,45					33	7	25,5	470	3	7,4
BA-DX HE 60 LV/RV	4.400	109	2,45	33,2	6	25,8	476	3,6	6,7				

## 7. INSPECTION, MAINTENANCE AND CLEANING

### 7.1. FILTERS

#### Replacement

The registers ubication for filters maintenance depends on the model and version. The exact ubication of the filters is identified by a label in the profile that indicates the type of filter and its characteristics.



#### FALLING OBJECTS

**By loosening the screws that hold the panels, they will be released. In units installed in ceiling, pay special attention to this operation to prevent the fall of a panel. During the maintenance signaling the area below the heat recovery unit and prevent personnel access to it.**

- **Horizontal configurations of CADB/T-HE 04 to 33.** The access to filters can be done by the lateral panels and /or by the bottom panels (depending on the model):

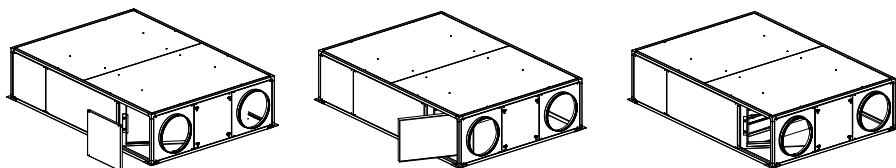

Quick access to filters from the lateral panels.

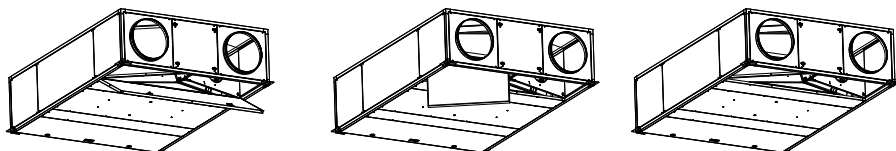

Quick access to filters from the bottom panels.

- **Horizontal configurations of CADB/T-HE 45 and 60.** The access to filters can be done by the side panels:

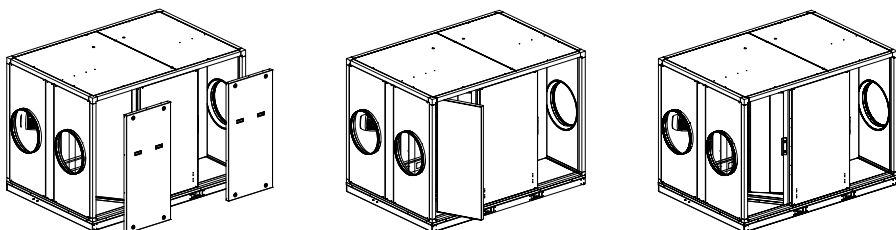

- **Vertical configurations of CADB/T-HE 45, 60 and 100.** The access to filters can be done by two sides of the unit, removing the specific panels selon in the following image:

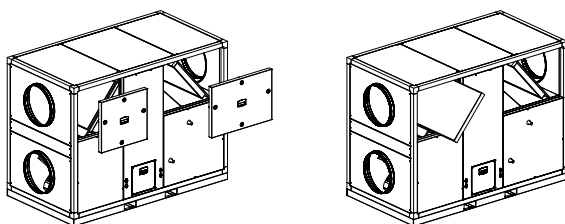

Replacement filters are delivered in a plastic bag for extra protection. Remove the bag before installing the filter into the unit.

Before installing the filter make sure that the airflow direction is correct. (indicated by an arrow in the filter).

## Filters parts table

Heat recovery model	Ø (mm)	AFR-HE (Accessory filters and spare part for CADB/T-HE)			
		AFR-HE G4	AFR-HE M5	AFR-HE F7	AFR-HE F9
CADB-HE D/DI/DC 04	200	AFR-HE 200/04 G4	AFR-HE 200/04 M5	AFR-HE 200/04 F7	AFR-HE 200/04 F9
CADB-HE D/DI/DC 08	250	AFR-HE 250/08 G4	AFR-HE 250/08 M5	AFR-HE 250/08 F7	AFR-HE 250/08 F9
CADB-HE D/DI/DC 12	315	AFR-HE 315/12 G4	AFR-HE 315/12 M5	AFR-HE 315/12 F7	AFR-HE 315/12 F9
CADB-HE D/DI/DC 16	315	AFR-HE 315/16 G4	AFR-HE 315/16 M5	AFR-HE 315/16 F7	AFR-HE 315/16 F9
CADB/T-HE D/DI/DC 21	400	AFR-HE 400/21-27 G4	AFR-HE 400/21-27 M5	AFR-HE 400/21-27 F7	AFR-HE 400/21-27 F9
CADB/T-HE D/DI/DC 27	400	AFR-HE 400/21-27 G4	AFR-HE 400/21-27 M5	AFR-HE 400/21-27 F7	AFR-HE 400/21-27 F9
CADT-HE D/DI/DC 33	400	AFR-HE 400/33 G4	AFR-HE 400/33 M5	AFR-HE 400/33 F7	AFR-HE 400/33 F9
CADT-HE-D/DI/DC 45	600x400	AFR-HE 450/45 G4	AFR-HE 450/45 M5	AFR-HE 450/45 F7	AFR-HE 450/45 F9
CADT-HE-D/DI/DC 60	700x500	AFR-HE 500/60 G4	AFR-HE 500/60 M5	AFR-HE 500/60 F7	AFR-HE 500/60 F9
CADT-HE D/DI/DC 100	1100x650	AFR-HE 710/100 G4	AFR-HE 710/100 M5	AFR-HE 710/100 F7	AFR-HE 710/100 F9

## 7.2. FILTER INSTALLATION

The heat recovery is supplied with mounted filters. Low pressure F7 filter for supply air and M5 for extract air. Possibility of mounting a second filter as accessory.

### Installation additional filter:

1. Loosen the two sets of filter support brackets (A).
2. Remove the filter holder (B).
3. Fit the second filter (C) ensuring that the direction of air is correct (indicated in the frame of the filter).
4. Ensure that the first filter the air passes is the lower grade of filtration.
5. Once both filters have been through fitted place the filter supports (B) symmetrically and tighten the 4 brackets (A).

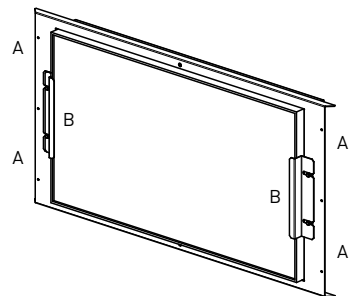
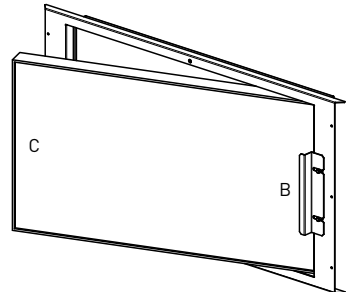
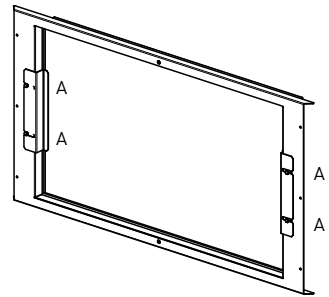

### 7.3. HEAT EXCHANGER

#### Horizontal models CADB/T HE 04 to 33

To perform the heat exchanger cleaning it is necessary to remove it from the unit. The disassembly can be easily done from the lateral panel:

#### Disassembly sequence

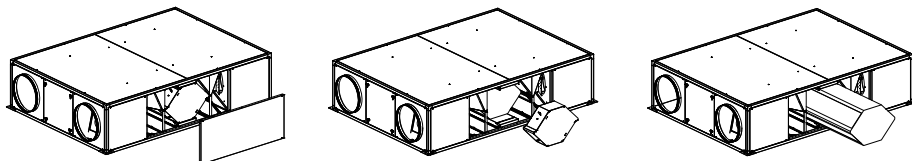

Models 04 to 33: Access to heat exchanger cleaning from lateral panels and from the bottom panels.

Need for disassembly of the heat exchanger.

45 and 60 models: Access for cleaning the heat exchanger from the side panels.

Alternatively, it is possible to disassemble the heat exchanger from the bottom panels. However, it is necessary to perform a major number of operations to proceed.

#### Access to the heat exchanger for bottom sequence

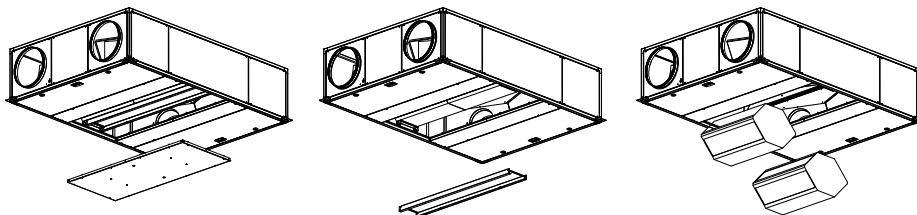

#### FALLING OBJECTS

By loosening the screws that hold the panels, those will be released. In units installed in ceiling, pay special attention to this operation to prevent the fall of a panel. During the maintenance, signaling the area below the heat recovery unit and prevent personnel access to it.

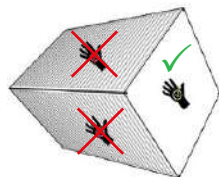

Not manipulate the heat exchanger for the finned area.



### Horizontal models CADB/T-HE 45 and 60

Due to the dimensions and weight of heat exchanger, the cleaning of it has to be perform in situ, without disassembly the heat exchanger.

To access to the heat exchanger, disassembly the side panels of the heat recovery unit and proceed with the cleaning by blowing with compressed air.

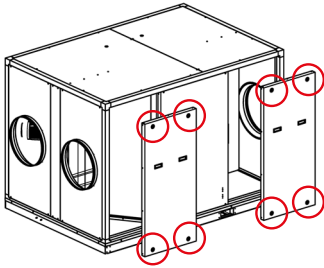

Loose the 4 closures that fix the access panel and remove the panel

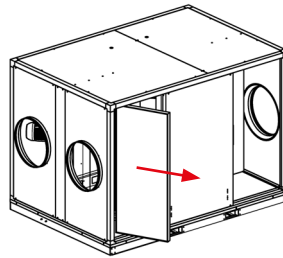

Loose the screws that fix the filter and after released, remove it. Clean the heat exchanger with blowing with compressed air

### Vertical models CADB/T-HE 04 to 100

Due to the dimensions and weight of heat exchanger, the cleaning of it has to be perform in situ, without disassembly the heat exchanger.

To access to the heat exchanger, disassembly the side panels of the heat recovery unit and proceed with the cleaning by blowing with compressed air.

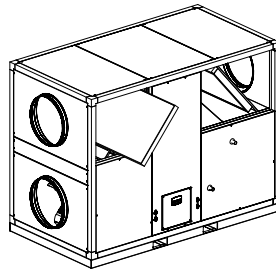
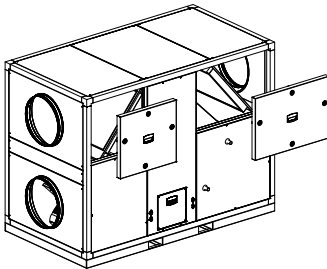

## 7.4. CONDENSATION DRAINPIPE

Inspect the drainpipe regularly and make sure it is not blocked, if this is the case, remove the obstruction.

Check that the drain pipe was done according to the indication included in the point CONNECTIONS of this manual.

The siphon should always be full of water. Check its level periodically, refilling it if necessary. An empty siphon can cause the condensate tray to overflow and water leak through the equipment enclosure.

## 8. OPERATION ANOMALIES

### 8.1. GENERAL ANOMALIES

Anomaly	Cause	Solution
Difficult to start.	Reduced power supply voltage. Insufficient static torque of motor.	Check motor specification plate. Close the air inlets to reach the maximum speed. Change the motor if necessary. Contact the <b>S&amp;P</b> Post-Sales service.
Insufficient airflow. Insufficient pressure.	Blocked pipes and/or inlet points closed. Fan obstructed. Filter overloaded. Insufficient rotation speed. Exchanger package blocked.	Clean inlet tubes. Clean fan. Clean or replace filter. Check power supply voltage. Clean the exchanger.
Reduction in performance after a period of acceptable operation.	Leaks in the circuit before and/or after the fan. Damaged roller.	Check the circuit and restore original conditions. Check the impeller and if necessary, replace with an original spare part. Contact the <b>S&amp;P</b> post sales service.
New air temperature too cold.	Outside air $-5^{\circ}\text{C}$ or less. Models (CADB/T DI): Thermal protectors Support resistances open.	Insertion of post-heating resistances. Contact the <b>S&amp;P</b> post sales service. Reset by pushing the button RESET, all the thermal protectors of the resistance.
Insufficient performance of the exchanger.	Fins dirty.	Clean the exchanger.
Formation of frost on the exchanger.	Outside air below $-5^{\circ}\text{C}$ .	Insertion of pre-heating devices (anti-ice). Contact the <b>S&amp;P</b> Customer Advice service.
Air pulsation.	Fan working in excessively low flow conditions. Flow instability, obstruction or bad connection.	Modification of the circuit and/or replacement of the fan. Clean and/or readjust the inlet channels. Operate the electronic regulator, increasing the minimum speed (insufficient voltage). Contact the <b>S&amp;P</b> Customer Advice service.
There is water inside the unit.	Drain clogged or wrongly dimensioned.	Check if exists a body/object obstructing the passage of water and remove it. Verify that the drain trap exists and is correctly sized according to the instructions of this manual.
	Only DC versions. Internal breakage of water coil.	Isolate the battery using the isolation valves. Repair the leak/ Replace the battery.
	Only DC version. The water coil is being used for cooling purpose with cold water.	The CADB-HE DC heat recovery can be used just for post-heating function with hot water.



**S&P SISTEMAS DE VENTILACIÓN, S.L.U.**

C. Llevant, 4  
Polígono Industrial Llevant  
08150 Parets del Vallès  
Barcelona - España

Tel. +34 93 571 93 00  
Fax +34 93 571 93 01  
[www.solerpalau.com](http://www.solerpalau.com)



Ref. 7081014900